

REQUEST FOR Planning Commission Action



PLANNING COMMISSION MEETING DATE:

SEPTEMBER 28, 2020

TITLE:

PUBLIC HEARING – CONDITIONAL USE PERMIT NO. 2020-17 AND VARIANCE NO. 2020-03 TO FACILITATE THE EXPANSION OF AN EXISTING INDUSTRIAL MEDICAL CLINIC LOCATED AT 1619 EAST EDINGER AVENUE INTO TWO ADJACENT TENANT SPACES AT 1621 AND 1623 EAST EDINGER AVENUE – EDWIN MOHABIR, APPLICANT

Prepared by Jerry C. Guevara

A blue ink signature of Jerry C. Guevara.

Executive Director

PLANNING COMMISSION SECRETARY

APPROVED

- As Recommended
- As Amended
- Set Public Hearing For _____

DENIED

- Applicant's Request
- Staff Recommendation

CONTINUED TO _____

A blue ink signature of the Planning Manager.

Planning Manager

RECOMMENDED ACTION

1. Adopt a resolution approving Conditional Use Permit No. 2020-17 as conditioned to allow the expansion of an existing industrial medical clinic; and
2. Adopt a resolution approving Variance No. 2020-03 as conditioned to allow a reduction in required off-street parking.

Summary of Updates and Changes to the Project

At its regular meeting on August 24, 2020, and after receiving public testimony on the project, the Planning Commission by a vote of 6:0:1 (Phan absent) continued the project to provide additional time for staff and the applicant to address additional exterior site improvements, parking and lighting concerns raised by the Planning Commission.

Following the Planning Commission hearing, staff and the applicant worked together to identify additional areas to install landscaping. In addition to a new five-foot landscape strip along the entire lot frontage on Edinger Avenue, the applicant is proposing to install new landscaping along the west elevation of the building that will include trellis with climbing vines, and place landscape pots along the front elevation of the building (Exhibits C and D). In addition, a new condition of approval (Condition No. 6 to the conditional use permit) has been added to address lighting concerns raised by the Planning Commission. The applicant will be required to submit a photometric plan in compliance with the City's Building Security Ordinance to the Planning Division and Police Department for approval.

To address the concerns of the Planning Commission regarding parking, the applicant contacted the adjacent property owners to obtain a reciprocal parking agreement but was unsuccessful in

obtaining approval from the adjacent owners. Per corporate practice, in the event that parking becomes an issue, the applicant will divert patients to one of their nearby clinics. Two locations nearby include 800 North Tustin Avenue (located three miles away) and 3100 West Warner Avenue (located five miles away). The Parking Demand Analysis has been modified to reflect these changes (Exhibit D).

Lastly, in order to ensure that the project does not deviate from the planned operations, additional conditions of approval have been added to limit the number of employees in a given time to thirteen employees. Staff will review the project six months after the date of issuance of the certificate of occupancy to ensure no impacts are being generated to adjacent properties and that the landscaping and lighting improvements remain in good condition. Should staff identify site deficiencies and parking issues, the project will be presented to the Planning Commission for further review and potential modifications to the conditions of approval.

Conclusion

Based on the analysis provided within this report, staff recommends that the Planning Commission approve Conditional Use Permit No. 2020-17 and Variance No. 2020-03 as conditioned.

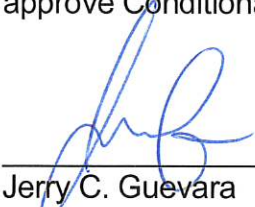

Jerry C. Guevara
Assistant Planner I

JG:S:\Planning Commission\2020\09-28-20\CUP No. 2020-17 & VA No. 2020-03 for Cocentra at 1619 E. Edinger Ave\CUP No. 2020-17 & VA No. 2020-03 for Concentra.RFPCA.doc

- Exhibits:
- A – CUP No. 2020-17 Resolution
 - B – VA No. 2020-03 Resolution
 - C – Revised Landscape Plans
 - D – Proposed Renderings
 - E – Revised Parking Demand Analysis
 - F – Planning Commission Staff Report & Exhibits Dated August 24, 2020

EXHIBIT 1

RESOLUTION NO. 2020-xx

A RESOLUTION OF THE PLANNING COMMISSION OF THE CITY OF SANTA ANA APPROVING CONDITIONAL USE PERMIT NO. 2020-17 AS CONDITIONED TO ALLOW THE EXPANSION OF AN EXISTING INDUSTRIAL MEDICAL CLINIC LOCATED AT 1619 EAST EDINGER AVENUE INTO TWO ADJACENT TENANT SPACES LOCATED AT 1621 AND 1623 EAST EDINGER AVENUE

BE IT RESOLVED BY THE PLANNING COMMISSION OF THE CITY OF SANTA ANA AS FOLLOWS:

Section 1. The Planning Commission of the City of Santa Ana hereby finds, determines and declares as follows:

- A. Edwin Mohabir, representing Concentra Health Services, Inc. ("Applicant"), is requesting approval of Conditional Use Permit (CUP) No. 2020-17 to allow the expansion of an existing 3,200-square industrial medical clinic located at 1619 East Edinger Avenue into two adjacent tenant spaces located at 1621 and 1623 East Edinger Avenue. The total floor area of the entire completed facility will be 9,600 square feet.
- B. Pursuant to Santa Ana Municipal Code (SAMC) Section 41-472.5(j), industrial medical clinics within the Light Industrial (M1) zoning district require approval of a CUP.
- C. Pursuant to SAMC Section 41-638, the Planning Commission is authorized to review and approve the CUP for this project as set forth by the SAMC.
- D. On August 24, 2020 and September 28, 2020, the Planning Commission held a duly noticed public hearing for CUP No. 2020-17.
- E. The Planning Commission of the City of Santa Ana has considered the information and determines that the following findings, which must be established in order to grant CUP No. 2020-17, for an industrial medical clinic, have been established as required by SAMC Section 41-638:
 1. That the proposed use will provide a service or facility which will contribute to the general well being of the neighborhood or community.

The proposed expansion of an existing industrial medical clinic will provide a service to persons and families that are working or residing in the area. The clinic will provide a benefit to the community by providing needed services to the targeted

population. Concentra provides occupational health, physical therapy, and urgent cares services.

2. That the proposed use will not, under the circumstances of the particular case, be detrimental to the health, safety, or general welfare of persons residing or working in the vicinity.

The proposed expansion of the existing industrial medical clinic will not be detrimental to the health, safety or welfare of those residing or working in the vicinity. The facility will be operated within an existing commercial and industrial building and the proposed expansion and its operations are compatible with nearby commercial and industrial uses. Impacts are not anticipated from the project.

3. That the proposed use will not adversely affect the present economic stability or future economic development of properties surrounding the area.

The industrial medical clinic will not adversely affect the economic stability or future economic development of properties in the surrounding area. The proposed industrial medical clinic expansion will occupy a vacant tenant space which will help re-establish economic use of the property and help activate the industrial center. The project also includes exterior improvement investments that will improve the appearance and economic stability of the area.

4. That the proposed use will comply with the regulations and conditions specified in Chapter 41 for such use.

The proposed use complies with the regulations and conditions in Chapter 41 (Zoning) of the SAMC. As part of this application, the Applicant is proposing to conduct exterior and interior improvements to the site. The M1 zoning district allows for industrial medical clinics subject to a conditional use permit. The use is similar in nature to other uses that are permitted within the M1 zoning district. A condition of approval has been added to require front yard landscaping and a property maintenance agreement to be recorded against the property which will ensure that the property and all improvements are properly maintained.

5. That the proposed use will not adversely affect the General Plan of the city or any specific plan applicable to the area of the proposed use.

The expanded industrial medical clinic will not adversely affect the General Plan. The project is located within the Industrial (IND) General Plan land use designation which plays a vital component to the city's economic health. These areas provide

employment opportunities for local residents, and generate municipal revenues for continued economic growth. Typical uses found in this district include light and heavy product manufacturing and assembly and commercial uses which are ancillary to industrial uses in the district. Approval of the CUP will be consistent with several goals and policies of the General Plan. Policy 2.2 of the Land Use Element encourages land uses that accommodate the City's needs for goods and services, and Policy 5.5 encourages development that is compatible with and supporting of surrounding land uses. The proposed industrial medical clinic expansion will continue to allow Concentra to provide needed services to the City's residents and workers.

Section 2. In accordance with the California Environmental Quality Act (CEQA) and the CEQA Guidelines, the project is categorically exempt from further review per Section 15301 (Class 1 – Existing Facilities) of the CEQA Guidelines. The Class 1 exemption applies to the operation, repair, maintenance, permitting, leasing, licensing, or minor alteration of existing private structures involving negligible or no expansion of the use. The existing 12,800-square foot building is within the M1 zone which allows for such use. The proposed industrial medical clinic does not involve an expansion in use since the building has been utilized by similar industrial medical clinic uses in the past. As a result, Categorical Exemption, Environmental Review No. 2019-110 will be filed for this project.

Section 3. The Applicant shall indemnify, protect, defend and hold the City and/or any of its officials, officers, employees, agents, departments, agencies, authorized volunteers, and instrumentalities thereof, harmless from any and all claims, demands, lawsuits, writs of mandamus, referendum, and other proceedings (whether legal, equitable, declaratory, administrative or adjudicatory in nature), and alternative dispute resolution procedures (including, but not limited to arbitrations, mediations, and such other procedures), judgments, orders, and decisions (collectively "Actions"), brought against the City and/or any of its officials, officers, employees, agents, departments, agencies, and instrumentalities thereof, that challenge, attack, or seek to modify, set aside, void, or annul, any action of, or any permit or approval issued by the City and/or any of its officials, officers, employees, agents, departments, agencies, and instrumentalities thereof (including actions approved by the voters of the City) for or concerning the project, whether such Actions are brought under the Ralph M. Brown Act, California Environmental Quality Act, the Planning and Zoning Law, the Subdivision Map Act, Code of Civil Procedure sections 1085 or 1094.5, or any other federal, state or local constitution, statute, law, ordinance, charter, rule, regulation, or any decision of a court of competent jurisdiction. It is expressly agreed that the City shall have the right to approve, which approval will not be unreasonably withheld, the legal counsel providing the City's defense, and that Applicant shall reimburse the City for any costs and expenses directly and necessarily incurred by the City in the course of the defense. City shall promptly notify the Applicant of any Action brought and City shall cooperate with Applicant in the defense of the Action.

Section 4. Conditional Use Permit No. 2020-17 shall not be effective unless and until the Planning Commission reviews and approves Variance No. 2020-03. If said approvals are held to be invalid or unconstitutional by the decision of any court of competent jurisdiction, or otherwise denied, then this conditional use permit shall be null and void and have no further force and effect.

Section 5. The Planning Commission of the City of Santa Ana after conducting the public hearing hereby approves CUP No. 2020-17, as conditioned in Exhibit A, attached hereto and incorporated herein for the project located at 1619, 1621 and 1623 East Edinger Avenue. This decision is based upon the evidence submitted at the abovesaid hearing, which includes, but is not limited to: the Request for Planning Commission Action dated August 24, 2020 and September 28, 2020, and exhibits attached thereto; and the public testimony, written and oral, all of which are incorporated herein by this reference.

ADOPTED this 28th day of September, 2020.

AYES: Commissioners:
NOES: Commissioners:
ABSENT: Commissioners:
ABSTENTIONS: Commissioners:

Mark McLoughlin
Chairperson

APPROVED AS TO FORM:
Sonia R. Carvalho, City Attorney

By: _____
Lisa Storck
Assistant City Attorney

CERTIFICATE OF ATTESTATION AND ORIGINALITY

I, SARAH BERNAL, Recording Secretary, do hereby attest to and certify the attached Resolution No. 2020-xx to be the original resolution adopted by the Planning Commission of the City of Santa Ana on September 28, 2020.

Date: _____

Recording Secretary
City of Santa Ana

EXHIBIT A

Conditions of Approval for Conditional Use Permit No. 2020-17

Conditional Use Permit No. 2020-17 for an industrial medical clinic use is approved subject to compliance, to the reasonable satisfaction of the Executive Director of the Planning and Building Agency, with applicable sections of the Santa Ana Municipal Code, the California Administrative Code, the California Building Standards Code, and all other applicable regulations. In addition, the following conditions of approval shall be met:

The Applicant must comply with each and every condition listed below prior to exercising the rights conferred by this conditional use permit.

1. All proposed site improvements must conform to the Development Project Review (DP No. 2019-45) and the staff report exhibits are incorporated herein by reference.
2. Any amendment to this conditional use permit must be submitted to the Planning Division for review. At that time, staff will determine if administrative relief is available or if the conditional use permit must be amended.
3. Staff will review the project six months after the date of issuance of the certificate of occupancy to ensure no impacts are being generated to adjacent properties and that the condition of landscape and lighting improvements is in good order. Should staff identify site deficiencies or parking issues, the project will be rescheduled at the Applicant's expense to allow the Planning Commission the opportunity to modify the conditions of approval as needed.
4. The operation of the industrial medical clinic is also subject to Variance No. 2020-03, as conditioned.
5. Prior to the issuance of a Building Permit, the Applicant shall submit a landscape and irrigation plan to the Planning Division for review and approval. The landscape and irrigation shall comply with the zoning district's landscape standards, the Water Efficient Landscape Ordinance (WELO), and the Citywide Design Guidelines.
6. Prior to the issuance of a Building Permit, the Applicant shall submit a photometric plan to the Planning and Building Agency and Police Department for review and approval. The photometric plan shall comply with Chapter 8, Article II, Division 3 of the Santa Ana Municipal Code (Building Security Ordinance).
7. Prior to the issuance of a Building Permit, a Property Maintenance Agreement must be recorded against the property. The agreement will be subject to review and applicability by the Planning and Building Agency, the Community Development Agency, the Public Works Agency, and the City Attorney to ensure that the property and all improvements located thereupon are properly maintained, Developer/Applicant (and the owner of the property upon which the authorized use and/or authorized improvements are located if different from the Applicant) shall execute a Maintenance Agreement with the City of Santa Ana which shall be recorded against the property and which shall be in a form

reasonably satisfactory to the City Attorney. The Maintenance Agreement shall contain covenants, conditions and restrictions relating to the following:

- a. Compliance with operational conditions applicable during any period(s) of construction or major repair (e.g., proper screening and securing of the construction site; implementation of proper erosion control, dust control and noise mitigation; adherence to approved project phasing etc.), if applicable;
- b. Compliance with ongoing operational conditions, requirements and restrictions, as applicable (including but not limited to hours of operation, security requirements, the proper storage and disposal of trash and debris, enforcement of the parking management plan, and/or restrictions on certain uses) if applicable;
- c. Ongoing compliance with approved design and construction parameters, signage parameters and restrictions as well as landscape designs, as applicable;
- d. Ongoing maintenance, repair and upkeep of the property and all improvements located thereupon (including but not limited to controls on the proliferation of trash and debris about the property; the proper and timely removal of graffiti; the timely maintenance, repair and upkeep of damaged, vandalized and/or weathered buildings, structures and/or improvements; the timely maintenance, repair and upkeep of exterior paint, parking striping, lighting and irrigation fixtures, walls and fencing, publicly accessible bathrooms and bathroom fixtures, landscaping and related landscape improvements and the like, as applicable;
- e. If Developer/Applicant and the owner of the property are different (e.g., if the Applicant is a tenant or licensee of the property or any portion thereof), both the Applicant and the owner of the property shall be signatories to the Maintenance Agreement and both shall be jointly and severally liable for compliance with its terms;
- f. The Maintenance Agreement shall further provide that any party responsible for complying with its terms shall not assign its ownership interest in the property or any interest in any lease, sublease, license or sublicense, unless the prospective assignee agrees in writing to assume all of the duties, obligations and responsibilities set forth under the Maintenance Agreement; and
- g. The Maintenance Agreement shall contain provisions relating to the enforcement of its conditions by the City and shall also contain provisions authorizing the City to recover costs and expenses which the City may incur arising out of any enforcement and/or remediation efforts which the City may undertake in order to cure any deficiency in maintenance, repair or upkeep or to enforce any restrictions or conditions upon the use of the property. The maintenance agreement shall further provide that any unreimbursed costs and/or expenses incurred by the City to cure a

deficiency in maintenance or to enforce use restrictions shall become a lien upon the property in an amount equivalent to the actual costs and/or expense incurred by the City.

EXHIBIT 2

RESOLUTION NO. 2020-xx

A RESOLUTION OF THE PLANNING COMMISSION OF THE CITY OF SANTA ANA APPROVING VARIANCE NO. 2020-03 AS CONDITIONED ALLOWING A REDUCTION IN REQUIRED OFF-STREET PARKING TO FACILITATE EXPANSION OF AN EXISTING INDUSTRIAL MEDICAL CLINIC LOCATED AT 1619, 1621 AND 1623 EAST EDINGER AVENUE

BE IT RESOLVED BY THE PLANNING COMMISSION OF THE CITY OF SANTA ANA AS FOLLOWS:

Section 1. The Planning Commission of the City of Santa Ana hereby finds, determines and declares as follows:

- A. Edwin Mohabir, representing Concentra Health Services, Inc. ("Applicant"), is requesting approval of Variance (VA) No. 2020-03 to allow a reduction in required off-street parking for an industrial medical clinic located at 1619, 1621 and 1623 East Edinger Avenue.
- B. Pursuant to Santa Ana Municipal Code (SAMC) Section 41-1346, medical clinics are required to provide on-site parking at a rate of five spaces per 1,000 square feet of gross floor area. Based on this ratio, 54 parking spaces are required for the proposed industrial medical clinic and existing manufacturing use on-site. The Applicant is proposing to provide 40 parking spaces on-site, 26 percent less than the required on-site parking, therefore, requiring approval of a variance.
- C. Pursuant to SAMC 41-632, the Planning Commission is authorized to review and approve a variance for a reduction in off-street parking for the subject property and project as set forth by the SAMC.
- D. On August 24, 2020 and September 28, 2020, the Planning Commission held a duly noticed public hearing for VA No. 2020-03.
- E. The Planning Commission of the City of Santa Ana has considered the information and determines that the following findings, which must be established in order to grant VA No. 2020-03, for a reduction in required off-street parking, have been established as required by SAMC section 41-638:
 1. That because of special circumstances applicable to the subject property, including size, shape, topography, location or surroundings, the strict application of the zoning ordinance is found to deprive the subject property of privileges not otherwise at

variance with the intent and purpose of the provisions of this Chapter.

There are special circumstances related to the existing conditions of the property. In 1969, the building and site improvements were constructed which included a 12,800-square foot building. In order to meet the City's current off-street parking requirements for an industrial medical clinic, significant modifications to the building and site, such as demolishing portions of the building, would be required. Strict application of the off-street parking regulations would not allow the tenant to expand its operations and services to its customers. The parking analysis conducted by Overland Traffic Consultants, Inc., supports the intent of the code which is to provide sufficient off-street parking. The study indicates that there would be sufficient parking for the proposed use, therefore, no parking impacts to the nearby uses or properties will be created.

2. That the granting of a variance is necessary for the preservation and enjoyment of one (1) or more substantial property rights.

Granting this variance is necessary for the preservation and enjoyment of substantial property rights. Granting this variance will allow the property to continue and expand its use as an industrial medical clinic which will benefit the community at large. The use is compatible with surrounding land uses and will not be detrimental to the surrounding community.

3. That the granting of a variance will not be materially detrimental to the public welfare or injurious to surrounding property.

Granting this variance will not be detrimental to the public or surrounding properties. A parking analysis was conducted which concluded that a peak demand of 37 parking spaces would be needed for the combined land uses on-site. The peak demand has been determined to occur from 9:00 a.m. to 10:00 a.m., 12:00 p.m. to 2:00 p.m. and from 6:00 p.m. to 7:00 p.m. Based on the results of the parking analysis, a surplus of three (3) parking spaces will be provided on-site and the proposed 40 parking stalls are sufficient to meet the demand of both land uses. Furthermore, conditions of approval have been added to the variance which would mitigate, if there was any, impact to surrounding properties.

4. That the granting of a variance will not adversely affect the General Plan of the city.

The variance for a reduction in required off-street parking will not adversely affect the General Plan. The project is located within the Industrial (IND) General Plan land use designation which plays a vital component to the city's economic health. These areas provide employment opportunities for local residents, and generate municipal revenues for continued economic growth. Typical uses found in this district include light and heavy product manufacturing and assembly, and commercial uses which are ancillary to industrial uses in the district. Approval of the variance will be consistent with several goals and policies of the General Plan. The expanded industrial medical clinic will not adversely affect the General Plan. Policy 2.2 of the Land Use Element encourages land uses that accommodate the City's needs for goods and services and Policy 5.5 encourages development that is compatible with and supporting of surrounding land uses. The proposed industrial medical clinic expansion will continue to allow Concentra to provide needed services to the City's residents and workers.

Section 2. In accordance with the California Environmental Quality Act (CEQA) and the CEQA Guidelines, the project is categorically exempt from further review per Section 15301 (Class 1 – Existing Facilities) of the CEQA Guidelines. The Class 1 exemption applies to the operation, repair, maintenance, permitting, leasing, licensing, or minor alteration of existing private structures involving negligible or no expansion of the use. The existing 12,800-square foot building is within the M1 zone which allows for such use. The proposed industrial medical clinic does not involve an expansion in use since the building has been utilized by similar industrial medical clinic uses in the past. As a result, Categorical Exemption, Environmental Review No. 2019-110 will be filed for this project.

Section 3. The Applicant shall indemnify, protect, defend and hold the City and/or any of its officials, officers, employees, agents, departments, agencies, authorized volunteers, and instrumentalities thereof, harmless from any and all claims, demands, lawsuits, writs of mandamus, referendum, and other proceedings (whether legal, equitable, declaratory, administrative or adjudicatory in nature), and alternative dispute resolution procedures (including, but not limited to arbitrations, mediations, and such other procedures), judgments, orders, and decisions (collectively "Actions"), brought against the City and/or any of its officials, officers, employees, agents, departments, agencies, and instrumentalities thereof, that challenge, attack, or seek to modify, set aside, void, or annul, any action of, or any permit or approval issued by the City and/or any of its officials, officers, employees, agents, departments, agencies, and instrumentalities thereof (including actions approved by the voters of the City) for or concerning the project, whether such Actions are brought under the Ralph M. Brown Act, California Environmental Quality Act, the Planning and Zoning Law, the Subdivision Map Act, Code of Civil Procedure sections 1085 or 1094.5, or any other federal, state or

local constitution, statute, law, ordinance, charter, rule, regulation, or any decision of a court of competent jurisdiction. It is expressly agreed that the City shall have the right to approve, which approval will not be unreasonably withheld, the legal counsel providing the City's defense, and that Applicant shall reimburse the City for any costs and expenses directly and necessarily incurred by the City in the course of the defense. City shall promptly notify the Applicant of any Action brought and City shall cooperate with Applicant in the defense of the Action.

Section 4. Variance No. 2020-03 shall not be effective unless and until the Planning Commission reviews and approves Conditional Use Permit No. 2020-17. If said approvals are held to be invalid or unconstitutional by the decision of any court of competent jurisdiction, or otherwise denied, then this variance shall be null and void and have no further force and effect.

Section 5. The Planning Commission of the City of Santa Ana, after conducting the public hearing, hereby approves VA No. 2020-03 as conditioned in Exhibit A, attached hereto and incorporated as though fully set forth herein. This decision is based upon the evidence submitted at the above said hearing, which includes, but is not limited to: the Request for Planning Commission Action dated August 24, 2020 and September 28, 2020, and exhibits attached thereto; and the public testimony, written and oral, all of which are incorporated herein by this reference.

ADOPTED this 28th day of September, 2020.

AYES: Commissioners:

NOES: Commissioners:

ABSENT: Commissioners:

ABSTENTIONS: Commissioners:

Mark McLoughlin
Chairperson

APPROVED AS TO FORM:
Sonia R. Carvalho, City Attorney

By: _____
Lisa E. Storck
Assistant City Attorney

CERTIFICATE OF ATTESTATION AND ORIGINALITY

I, SARAH BERNAL, Recording Secretary, do hereby attest to and certify the attached Resolution No. 2020-xx to be the original resolution adopted by the Planning Commission of the City of Santa Ana on September 28, 2020.

Date: _____

Recording Secretary
City of Santa Ana

EXHIBIT A

Conditions of Approval for Variance No. 2020-03

Variance No. 2020-03 is approved subject to compliance, to the reasonable satisfaction of the Planning Manager, with applicable sections of the Santa Ana Municipal Code, the California Administrative Code, the California Building Standards Code, and all other applicable regulations. In addition, the following conditions of approval shall be met:

The Applicant must comply with each and every condition listed below prior to exercising the rights conferred by this variance.

1. All proposed site improvements must conform to the Development Project Review (DP No. 2019-45) and the staff report exhibits are incorporated herein by reference.
2. Any amendment to this variance must be submitted to the Planning Division for review. At that time, staff will determine if administrative relief is available or if the variance must be amended.
3. Staff will review the project six months after the date of issuance of the certificate of occupancy to ensure no impacts are being generated to adjacent properties and that the condition of landscape and lighting improvements is in good order. Should staff identify site deficiencies and parking issues, the project will be rescheduled at the Applicant's expense to allow the Planning Commission the opportunity to modify the conditions of approval as needed.
4. The operation of the industrial medical clinic is also subject to Conditional Use Permit No. 2020-17, as conditioned.
5. The maximum number of employees at a given time shall not exceed thirteen (13) individuals and 40 parking spaces shall be maintained on-site at all times. Should parking become an issue, patients shall be diverted by the occupant to a nearby facility as directed by the approved Parking Management Plan, attached hereto as Exhibit B.
6. Prior to the issuance of a Building Permit, the Applicant shall submit a landscape and irrigation plan to the Planning Division for review and approval. The landscape and irrigation shall comply with the zoning district's landscape standards, the Water Efficient Landscape Ordinance (WELo), and the Citywide Design Guidelines.
7. Prior to the issuance of a Building Permit, the Applicant shall submit a photometric plan to the Planning and Building Agency and Police Department for review and approval. The photometric plan shall comply with Chapter 8, Article II, Division 3 of the Santa Ana Municipal Code (Building Security Ordinance).
8. Prior to the issuance of a Building Permit, a Property Maintenance Agreement must be recorded against the property. The agreement will be subject to review and applicability by the Planning and Building Agency, the Community Development Agency, the Public Works Agency, and the City Attorney to ensure that the property

and all improvements located thereupon are properly maintained, Developer/Applicant (and the owner of the property upon which the authorized use and/or authorized improvements are located if different from the Applicant) shall execute a Maintenance Agreement with the City of Santa Ana which shall be recorded against the property and which shall be in a form reasonably satisfactory to the City Attorney. The Maintenance Agreement shall contain covenants, conditions and restrictions relating to the following:

- a. Compliance with operational conditions applicable during any period(s) of construction or major repair (e.g., proper screening and securing of the construction site; implementation of proper erosion control, dust control and noise mitigation; adherence to approved project phasing etc.), if applicable;
- b. Compliance with ongoing operational conditions, requirements and restrictions, as applicable (including but not limited to hours of operation, security requirements, the proper storage and disposal of trash and debris, enforcement of the parking management plan, and/or restrictions on certain uses) if applicable;
- c. Ongoing compliance with approved design and construction parameters, signage parameters and restrictions as well as landscape designs, as applicable;
- d. Ongoing maintenance, repair and upkeep of the property and all improvements located thereupon (including but not limited to controls on the proliferation of trash and debris about the property; the proper and timely removal of graffiti; the timely maintenance, repair and upkeep of damaged, vandalized and/or weathered buildings, structures and/or improvements; the timely maintenance, repair and upkeep of exterior paint, parking striping, lighting and irrigation fixtures, walls and fencing, publicly accessible bathrooms and bathroom fixtures, landscaping and related landscape improvements and the like, as applicable;
- e. If Developer/Applicant and the owner of the property are different (e.g., if the Applicant is a tenant or licensee of the property or any portion thereof), both the Applicant and the owner of the property shall be signatories to the Maintenance Agreement and both shall be jointly and severally liable for compliance with its terms;
- f. The Maintenance Agreement shall further provide that any party responsible for complying with its terms shall not assign its ownership interest in the property or any interest in any lease, sublease, license or sublicense, unless the prospective assignee agrees in writing to assume all of the duties, obligations and responsibilities set forth under the Maintenance Agreement; and
- g. The Maintenance Agreement shall contain provisions relating to the enforcement of its conditions by the City and shall also contain provisions

authorizing the City to recover costs and expenses which the City may incur arising out of any enforcement and/or remediation efforts which the City may undertake in order to cure any deficiency in maintenance, repair or upkeep or to enforce any restrictions or conditions upon the use of the property. The maintenance agreement shall further provide that any unreimbursed costs and/or expenses incurred by the City to cure a deficiency in maintenance or to enforce use restrictions shall become a lien upon the property in an amount equivalent to the actual costs and/or expense incurred by the City.

EXHIBIT 3

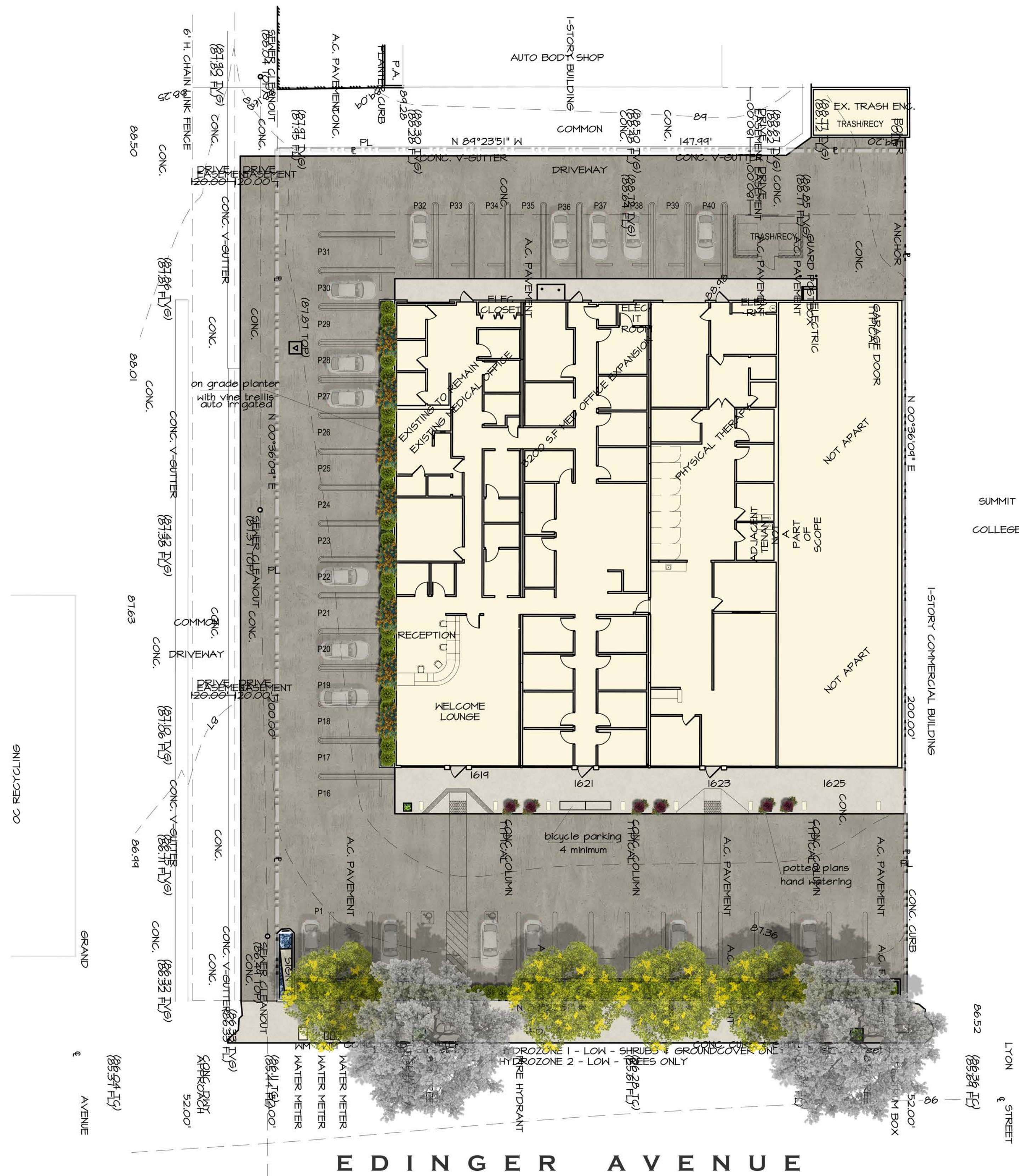

PLANTING PLAN

SCALE: 1/16" = 1'-0"

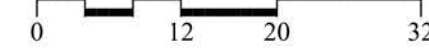

TREE LEGEND

SYMBOL	BOTANICAL NAME / WUCOLS COMMON NAME SIZE / QUANTITY / SIZE @ PLANTING / MAJORITY
	ZELKOVA SERRATA 'MUSASHINO' / LOW COLUMNAR SAWLEAF ZELKOVA 24 INCH BOX / 4 / 10' T X 3W / 40' T X 15W
	2 - EXISTING STREET TREES TO REMAIN PROTECT IN PLACE

SHRUB LEGEND

SYMBOL	BOTANICAL NAME COMMON NAME SIZE / QUANTITY / WUCOLS
	BOUGAINVILLEA 'ORANGE KING' ORANGE KING BOUGAINVILLEA - TRAIN ON TRELIS 15 GAL / 8 / 15' TALL X 15' WIDE / LOW
	CARISSA M. 'GREEN CARPET' LOW GROWING NATAL PLUM 1 GAL / 105 / 1-1.5' TALL X 4' WIDE / LOW
	CORDYLINE X 'JURred' FESTIVAL BURGUNDY CORYLINE 5 GAL / 7 / 3' TALL X 3' WIDE / LOW
	LANTANA C. 'MONIKE' TEENIE GENIE COMPACT LANTANA 1 GAL / 14 / 30" TALL X 30" WIDE / LOW

GROUNDCOVER LEGEND

SYMBOL	BOTANICAL NAME / WUCOLS COMMON NAME SIZE / QUANTITY
	MULCH 3" LAYER
	SEDUM S. 'DRAGON'S BLOOD' DRAGON'S BLOOD STONECROP FLATS / PLANT @ 18" O.C. EQ. TRIANGLE SPACING
	EXISTING PEBBLES AROUND SIGN

WATER PURVEYOR

SANTA ANA WATER SERVICES
20 CIVIC CENTER PLAZA
SANTA ANA, CA 92702

ROBERT HERNANDEZ
714-647-4700

LANDSCAPER AREA & PROJECT TYPE

TOTAL LANDSCAPE AREA: 572 SQUARE FEET
PROJECT TYPE: REHABILITATED -PRIVATE



ZELKOVA S. 'MUSASHINO'

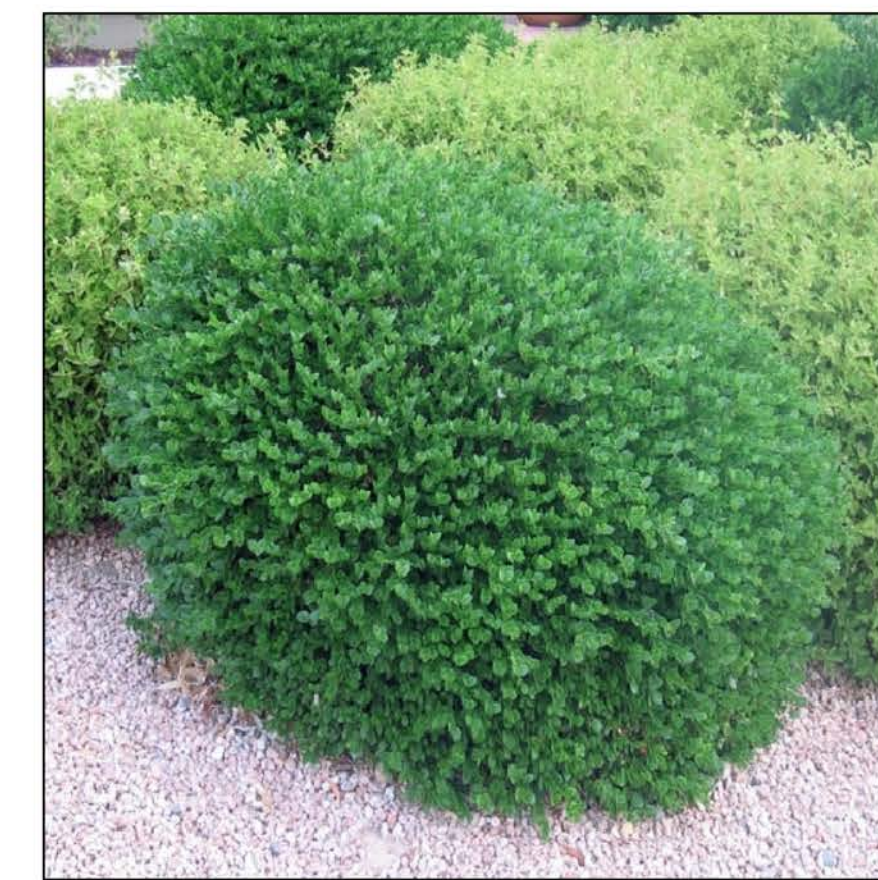

CARISSA M. 'BOXWOOD BEAUTY'



LANTANA C. 'MONIKE'



BOUGAINVILLEA 'ORANGE KING'



CORDYLINE X 'JURred'



SEDUM S. 'DRAGON'S BLOOD'



Susan E. McEowen
LANDSCAPE ARCHITECT

Susan E. McEowen
Landscape Architect 2180
A California Corporation
19197 Golden Valley Road, #924
Santa Clarita, CA 91387
Office: (661) 212-3335
Email: susan@landarch.us

MEDICAL BUILDING

1619 & 1623 E. EDINGER AVE.
SANTA ANA, CA. 92705

CONCENTRA

25124 SPRINGFIELD COURT, #200
VALENCIA, CA. 91355

2020-09-09

DATE

LP-1

PAGE

Project: 2020-09-09
 Design: Susan E. McEowen, Landscape Architect ©2020. The program and all
 information contained herein are the property of Susan E. McEowen, Landscape Architect.
 No part of this publication may be reproduced, stored in a retrieval system, or
 transmitted in any form or by any means, electronic, mechanical, photocopying,
 recording, or by any information storage and retrieval system, without the prior
 written permission of Susan E. McEowen, Landscape Architect.
 Project No.: 2020-09-09

EXHIBIT 4

CUP No. 2020-17 & VA No. 2020-03
1619, 1621 & 1623 E. Edinger Avenue



Exhibit D – Proposed Rendering

EXHIBIT 5

PARKING DEMAND STUDY

CONCENTRA

OCCUPATIONAL MEDICINE & URGENT CARE
1619, 1621, 1623 East Edinger Avenue
in the City of Santa Ana

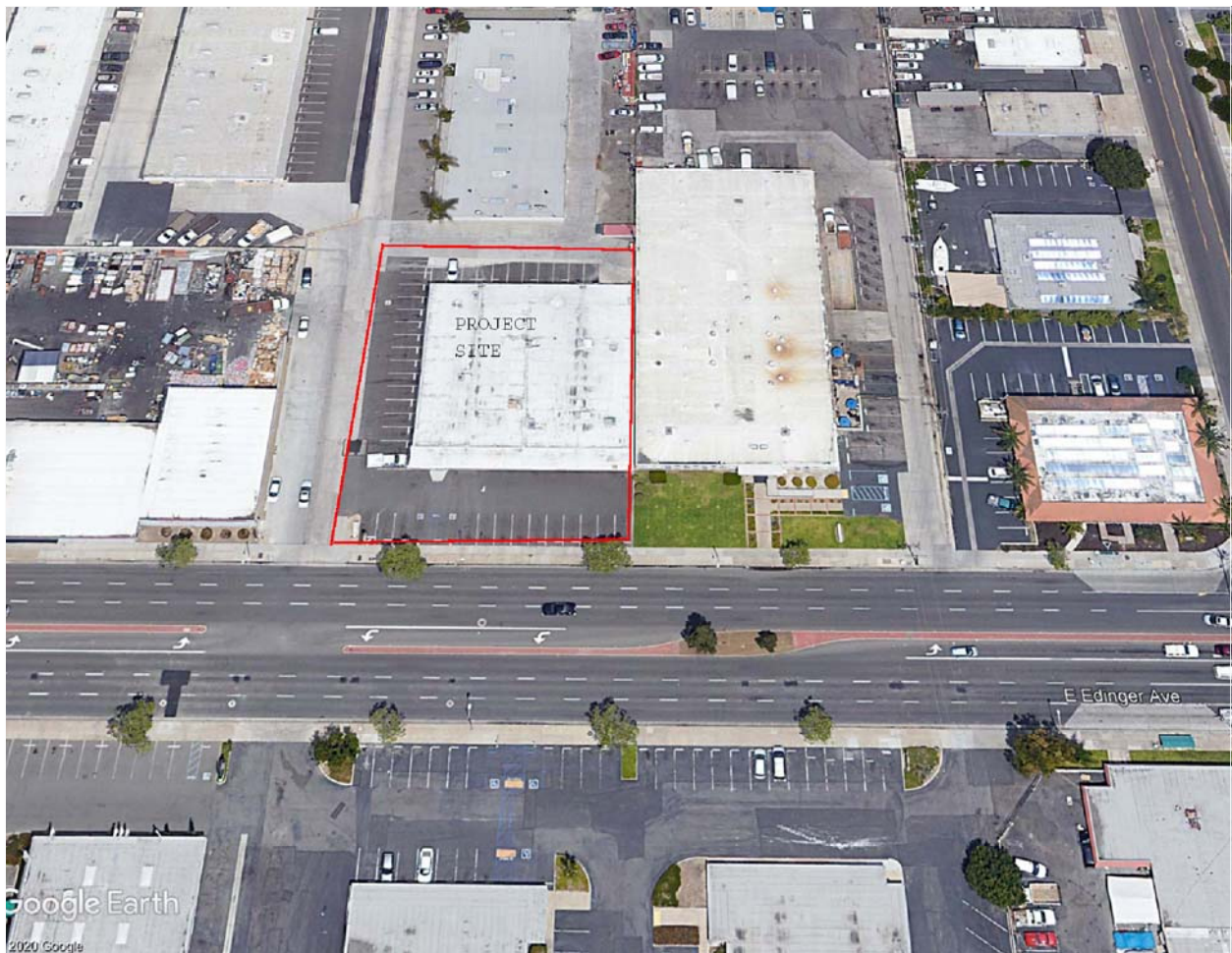

Google Earth

Prepared by:
Overland Traffic Consultants, Inc.
952 Manhattan Beach Bl, #100
Manhattan Beach, California 90266
(310) 545-1235

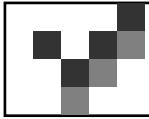

EXECUTIVE SUMMARY

This report provides an evaluation of the parking demand for the proposed project at a site located at 1619, 1621, 1623 and 1625 East Edinger Avenue in the City of Santa Ana. The Project is located on the north side of East Edinger Avenue between South Lyon Street and Grand Avenue. There is a 12,800 square foot building existing on the site. The building is separated into four 3,200 square foot units. A permitted and occupied 3,200 industrial medical office is located within the 1619 East Edinger Avenue space of the building and a 3,200 square foot manufacturing business operates within 1625 East Edinger Avenue space of the building. The Project will:

- Expand the existing industrial medical office by an additional 3,200 square feet in the 1621 East Edinger Avenue space; and
- Provide entitlements for the associated 3,200 square feet of physical therapy space within the 1623 East Edinger Avenue portion of the building.

Surface parking for the site is provided along the southern boundary of the site and along the east and north walls of the building. After modification for path of travel and trash enclosure, there will be a total of 40 shared parking spaces provided for the building. Vehicular access is provided from East Edinger Avenue with a driveway along the western boundary of the site that is shared with the neighboring uses.

The focus of this parking demand study is to determine the City of Santa Ana code required parking and determine if the 40 parking spaces provided on-site are sufficient to accommodate the peak parking demand of the Project along with the existing uses.

The City of Santa Ana code required vehicle parking is 54 spaces. Institute of Transportation Engineers parking demand for the land uses has been determined to be 40 spaces. Based on determined usage of the Project including employees and patients, it has been found that a peak parking demand of 37 parking spaces would be needed for the combined existing and project expansion uses. The peak demand has been determined to occur from 9 to 10 AM, Noon to 2 PM and from 6 to 7 PM. This peak demand would be accommodated on site with a surplus of 3 spaces.



PARKING DEMAND STUDY

DESCRIPTION

The focus of the parking demand study is to document the City of Santa Ana code required parking for the mixed-use building located at 1619, 1621, 1623 and 1625 East Edinger Avenue and to determine the potential future peak parking demand of the building at full occupancy. Incorporated into this analysis is a goal to continue to provide sufficient on-site parking availability to accommodate the peak demand.

The 12,800 square foot building at 1619, 1621, 1623 and 1625 is currently permitted and occupied by a 3,200 square foot industrial medical office and 3,200 square foot manufacturing use. The Project, if approved, will allow for a 3,200 square foot expansion of the industrial medical office and the permit additional, associated, 3,200 square feet of physical therapy offices. Upon completion the building will house 6,800 square feet of industrial medical office with associated physical therapy and 3,200 square feet of manufacturing. A copy of the site plan is provided in Attachment A

Perpendicular parking spaces are provided along the southern boundary of the site and along the east and north walls of the building. A total of 40 on-site surface parking spaces are provided. Vehicular access is provided to/from East Edinger Avenue via a shared driveway. A channelized left turn pocket is provided on East Edinger Avenue.

PARKING DEMAND ANALYSIS PROCESS

The first step was to determine current City of Santa Ana code-parking requirement for the Project and the site as a whole. The vehicle parking requirement is 2 spaces per 1,000 square feet for the manufacturing (Section 41-1390) and 5 spaces per 1,000 square feet for the medical office (Section 41.1346).

Parking demand for the site may be reduced by use of the transit opportunities, cycling and walking in the area. The employees and patrons on site have an opportunity to use of mass transit instead of personal vehicles. Figure 1 provides a map of the Orange County mass transit services in the area.



Figure 1 Transit Services (Focused Orange County Transit Map)

Parking demand for the building based on national standards of the Institute of Transportation Engineers Parking Demand Manual was then determined based on the individual land uses and size.

Hourly parking demand for the building was then determined based on the individual land uses within the building including existing uses at code required parking rate (due to inability to collect accurate current demand) and for the Project based on operator input regarding estimated number of employees and hours and patient appointment rates and length of stay.

The estimated parking demand in this study was not reduced by anticipated transit usage to provide a conservative estimate of demand.



CITY OF SANTA ANA CODE PARKING REQUIREMENT FOR SITE

City of Santa Ana parking requirements have been calculated by the applying Zoning Code parking rates (Section 41-1390 & (Section 41-1346) as provided below in Table 1:

Table 1
City of Santa Ana Current Zoning Code Requirements

Land Use	Size	Parking Parking Requirement	Code Required Parking
Existing			
Medical Office	3,200 sf	5 per 1,000 sf	16
Manufacturing	3,200 sf	2 per 1,000 sf	6
Subtotal Existing	6,400 sf		22
Proposed			
Medical Office Expansion	3,200 sf	5 per 1,000 sf	16
Physical Therapy	3,200 sf	5 per 1,000 sf	16
Subtotal Proposed	6,400 sf		32
Total Required	12,800 sf		54

There will be 40 parking spaces on-site with the Project. The building will have 14 fewer on-site parking spaces than would be required by City code. However, as provided in the following two sections, Institute of Transportation Engineers parking demand is within the limits of the parking supply and the proposed new uses operational parking demand for patients and employees hourly in addition to the existing use will be within the limits of the parking supply.

INSTITUTE OF TRANSPORTATION ENGINEERS PARKING DEMAND

The Institute of Transportation Engineers (ITE) publishes a Parking Demand Handbook that provides parking demand rates for many land uses. The demand in the handbook has been determined by collecting parking data at multiple sites throughout the day. Parking demand in the ITE Parking Demand Manual, 5th Edition for manufacturing is identified as 0.82 spaces per 1,000 square feet. Parking demand for medical clinics and medical/dental offices have also been evaluated in the manual. The average rate for a



clinic is 3.89 spaces per 1,000 square feet with 12 sites studied. The average rate for a medical/dental office is 3.23 per 1,000 square feet with 117 sites studied. The ITE clinic rate was used in the estimate of the parking demand instead of medical/dental office because it is higher. The ITE based building's parking demand is provided on the following in Table 2.

Table 2
ITE Demand

Land Use	Size	85th Percentile Demand	Code Required Parking
<u>Existing</u>			
Medical Office	3,200 sf	3.89 per 1,000 sf	12
Manufacturing	3,200 sf	0.82 per 1,000 sf	3
Subtotal Existing	6,400 sf		15
<u>Proposed</u>			
Medical Office Expansion	3,200 sf	3.89 per 1,000 sf	12
Physical Therapy	3,200 sf	3.89 per 1,000 sf	12
Subtotal Proposed	6,400 sf		24
Total Required	12,800 sf		39

There will be 40 parking spaces on-site with the Project which exceeds the ITE estimated parking demand by one space.

HOURLY PARKING DEMAND BASED ON OPERATIONAL USE

Parking demand for the project and the building as a whole at 1619, 1621, 1623 and 1625 East Edinger Avenue has been determined based on current estimated demand with the Project land use demand added.

Existing Demand

The existing land uses include the 3,200 square foot industrial medical office and 3,200 square foot manufacturing use. Optimally, the building site would be surveyed to determine the existing uses demand within the parking lot. Unfortunately, this report has been initiated during the coronavirus business shutdowns and government stay put request. Parking demand counts during this time would not be representative of a typical

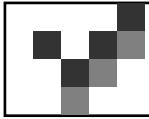

day. Therefore, existing parking demand was estimated as the code required parking for these two land uses. As shown in Table 1, existing parking demand is estimated as 22 parking spaces. In order to provide a conservative analysis, parking demand for every hour was estimated as 22 even though the demand would likely be smaller during different times of the day.

Project Demand

The Project parking demand was based on operations determined for the proposed 3,200 square foot industrial medical office expansion and the associated 3,200 square foot physical therapy office. Existing operators of the industrial medical office and physical therapy indicated the following:

Patients: 24 to 33 per day with 2 to 3 per hour

Employees: 9 new employees

The hours of operation are from 7 AM to 9 PM. As shown in Table 3 on the following page, the Project would create a parking demand of 11 to 15 parking spaces. When added to the existing parking demand for 22 spaces, the peak parking demand is 37 parking spaces. This peak occurs from 9 to 10 AM, noon to 2 PM and again in the evening from 6 to 7 PM. The building will have 6 more on-site parking spaces than would be needed according to parking demand based on operational use of the Project. Figure 2 on page 8, displays the hourly parking demand and found in Table 3 of the patients, the employees, the patients + employees, the existing uses and the combined total.

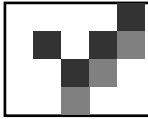

Table 3
SITE Parking Demand

40 Parking Spaces Provided

Time	Additon + Physical Therapy (Project)		Patients Parked	Employees Parked	Project Total Parking Demand	Existing Uses Parking Demand	Combined Demand Expansion + Existing	Parking Supply Available	Parking Surplus
	In	Out							
6 to 7 AM	0	0	0	0	0	0	40	40	
7 to 8 AM	2	0	2	9	11	22	33	40	7
8 to 9 AM	3	0	5	9	14	22	36	40	4
9 to 10 AM	3	-2	6	9	15	22	37	40	3
10 to 11 AM	2	-3	5	9	14	22	36	40	4
11 to Noon	3	-3	5	9	14	22	36	40	4
12 to 1 PM	3	-2	6	9	15	22	37	40	3
1 to 2 PM	3	-3	6	9	15	22	37	40	3
2 to 3 PM	2	-3	5	9	14	22	36	40	4
3 to 4 PM	2	-3	4	9	13	22	35	40	5
4 to 5 PM	2	-2	4	9	13	22	35	40	5
5 to 6 PM	3	-2	5	9	14	22	36	40	4
6 to 7 PM	3	-2	6	9	15	22	37	40	3
7 to 8 PM	2	-3	5	9	14	22	36	40	4
8 to 9 PM	0	-3	2	9	11	22	33	40	7
9 to 10 PM	0	-2	0	0	0	0	0	40	40

33 new patients per day

Stay estimated 2 hours per patient max

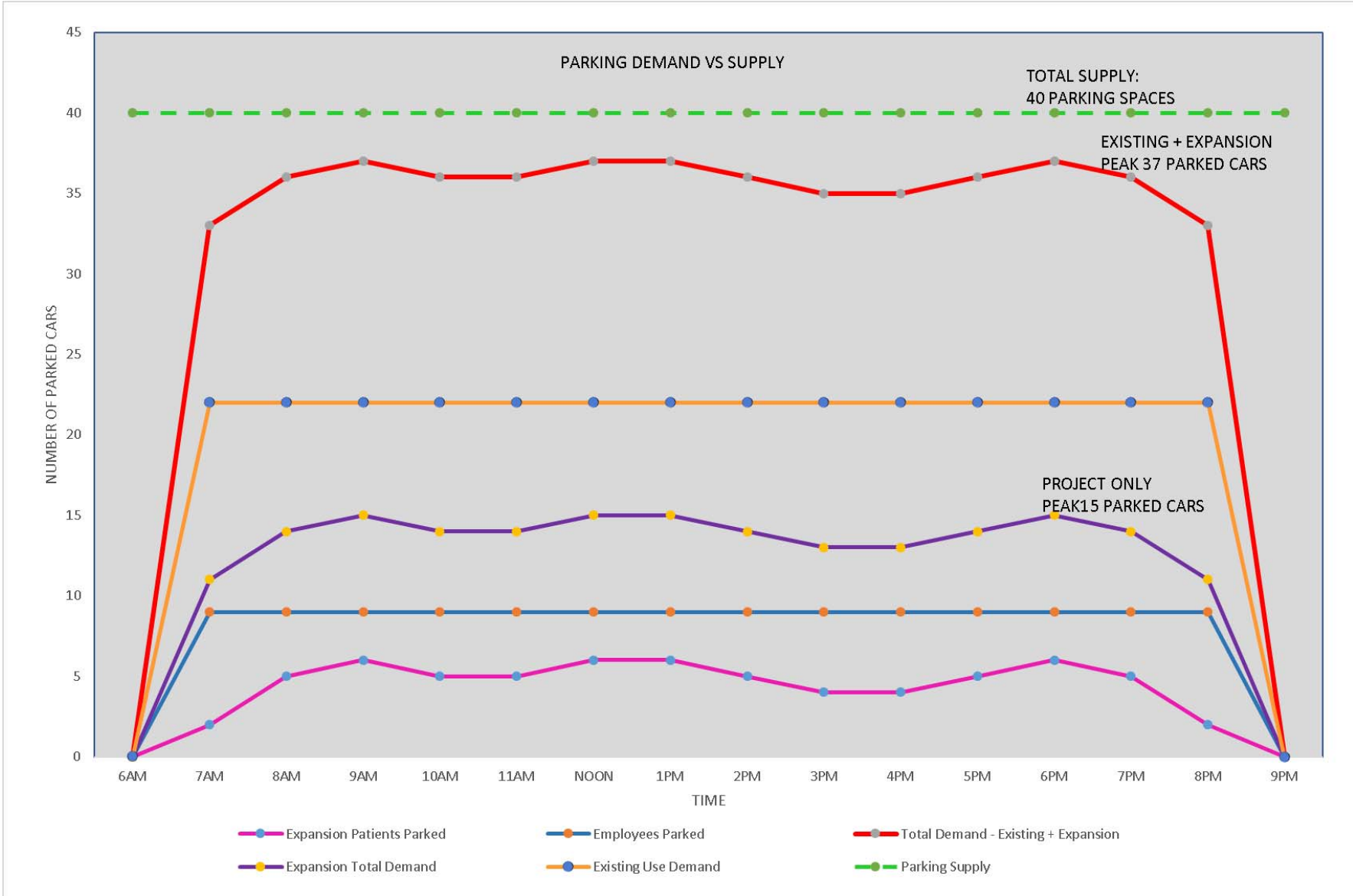

Figure 2, Chart of Hourly Parking Demand



PARKING DEMAND FINDINGS & SUMMARY

A demand parking analysis was conducted including the existing uses on site and the Project components including 40 parking spaces, 6,800 square feet of industrial medical office with associated physical therapy and 3,200 square feet of manufacturing.

- The site does not have enough parking to meet City code requirements for 54 parking.
- Enough parking is provided to meet estimated ITE Parking Demand of 39 spaces.
- Hourly parking demand based on operational use at 1619, 1621, 1623 and 1625 East Edinger Avenue site is estimated as a maximum of 37 parking spaces from 9 to 10 AM, noon to 2 PM and again in the evening from 6 to 7 PM.
- Peak parking demand for the site with the expansion of 3,200 square foot industrial medical office and 3,200 square foot physical therapy medical office is met with 3 surplus parking spaces.

PARKING MANAGEMENT PLAN

Any potential increase in patient count will be diverted to one of our other clinics nearby.

Two locations nearby include:

- 800 North Tustin Ave, Santa Ana, CA 92705 is located 3 miles away from the proposed facility.
- 3100 W. Warner Ave, Santa Ana CA 92704 located 5 miles away from the proposed facility.



Attachment A
Proposed Project Site Plan

PL COMMON DRIVEWAY

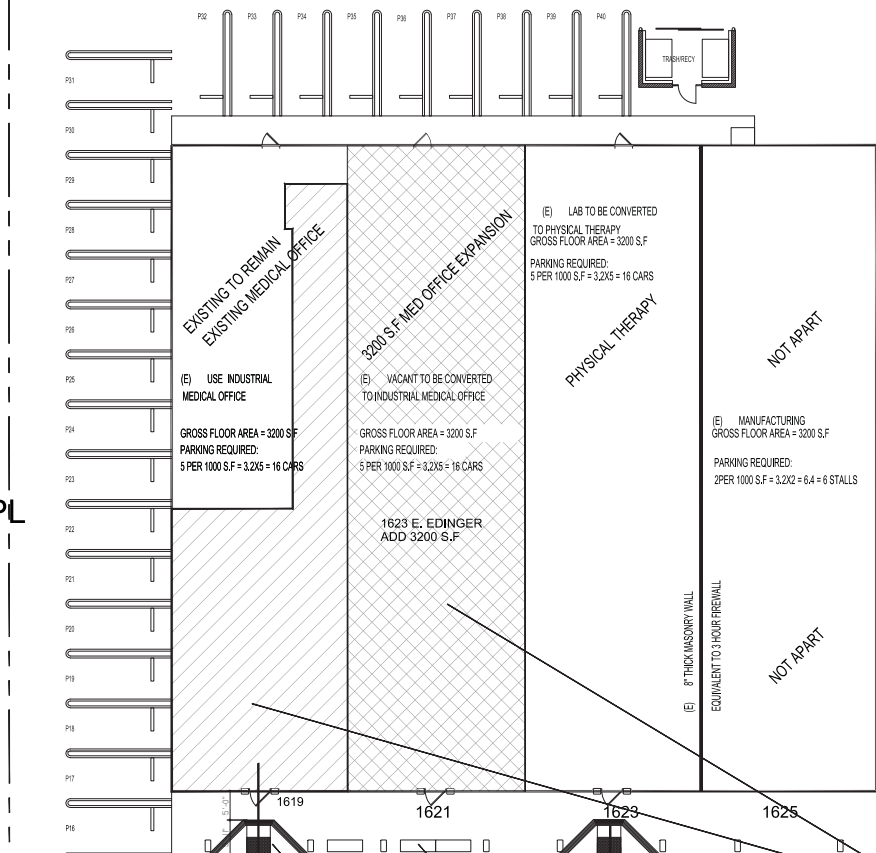

SUMMIT COLLEGE

ITEM # A6 - PARKING TABULATION

PARKING REQUIRED:

1619 E. EDINGER	16 STALLS
1621 E. EDINGER	16 STALLS
1623 E. EDINGER	16 STALLS
1625 E. EDINGER	6 STALLS
TOTAL REQUIRED	54 STALLS

PARKING PROVIDED 40 STALLS
 PARKING DEFICIT 14 STALLS
 PERCENTAGE DEFICIT 26
 VA REQUIRED

PROJECT DATA

Project Address:
 1619 E. Edinger Ave
 1621 E. Edinger Ave
 1623 E. Edinger Ave
 APN: 402-241-10

Applicant:
 Edwin Mohabir (323)459-8809

General Plan Land Use Designation Light Industrial
 Allowable FAR ?
 Zoning M1
 Total Lot Area 33,839 square feet 0.78 ac.
 Existing medical office = 3200 square feet
 Proposed medical expansion = 3200 square feet
 Proposed Physical Therapy = 3200 square feet
 Existing Manufacturing = 3200 square feet

Parking Tabulation:
 Gross floor area for all medical use = 9600 square feet
 Parking required 5 per 1000 s.f. = 48 stalls
 Manufacturing 2 per 1000 s.f. = 6.4 stalls
 Total parking required = 54 stalls
 Existing parking = 38 stalls
 Existing ADA complying stalls = 2 stalls
 Total provided = 40 stalls

Occupancy Type:
 1619 E. Edinger Ave Group B Occupancy
 1621 E. Edinger Ave Group B Occupancy proposed
 1623 E. Edinger Ave Group B Occupancy proposed
 1625 E. Edinger Ave Group F1 Occupancy
 Construction type Type VB
 Exterior walls Masonry
 Roof Materials Panelized roof with wood beams and purlins
 Non Sprinklered Building

There are no existing or proposed easements.
 There are no fence around the property.

SHEET INDEX:

- A-1.0 CUP PLOT PLAN
- A-1.1 SITE PLAN
- A-1.2 PARKING CALCULATIONS
- A-1.3 AREA CALCULATIONS
- A-2.0 EXITING FLOOR PLAN
- A-2.1 PROPOSED FLOOR PLAN
- A-2.2 OCCUPANT LOAD AND EXITING PLAN
- C-1 COVER SHEET
- C-2 UTILITY PLAN
- L-1 PLANTING PLAN
- L-2 IRRIGATION PLAN
- L-3 DETAILS
- L-4 DETAILS
- L-5 DETAILS
- L-6 NOTES

LEGEND

--- POT: Accessible path of travel as indicated on plan is a barrier free access route without any abrupt level changes exceeding 1/4" if bevel at 1:2 max. slope, or vertical level changes not exceeding 1/4" and at least 48" in width. The surface is stable, firm, and slip resistant. Cross slope does not exceed 2% and slope in the direction of travel is less than 5% slope, unless otherwise indicated. Landing at doorways shall be 2% max.

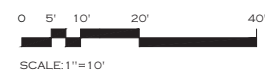

COMMON DRIVEWAY

PL

PL

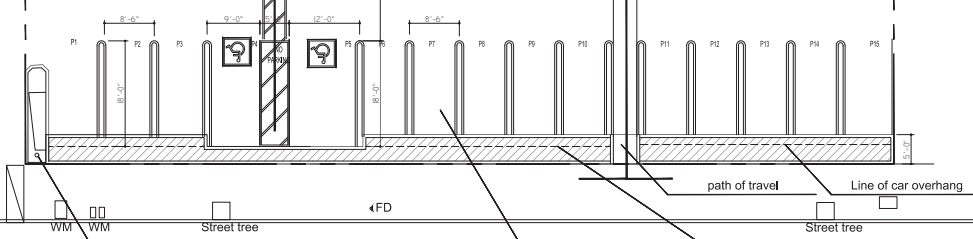

ITEM # A4 NON CONFORMING POLE SIGN TO BE REMOVED. MONUMENT SIGN IF DESIRED MUST COMPLY TO SECTION 41-862 OF THE S.M.C.

ITEM # A1 PARKING LOT RE-STRIPE PER SANTA ANA CITY STDS

ITEM # A2 & 3 LANDSCAPE SEE LANDSCAPE PLANS

COMBINED BLDG 1619 & 1621 = 6400 S.F.
 PER CBC 181.506.2 9000 S.F. ALLOWED FOR TYPE VB BUILDING COMPLES WITH AREA LIMITATION

EDWIN MOHABIR
EM
 ARCHITECT, INC.
 SANTA CLARITA, CA 91381
 2479 CONSTITUTION AVE. #1435
 EDWINMOHABIR@GMAIL.COM
 TEL: 323-459-8809

EXPOSED
 EDWIN MOHABIR
 C23674
 Exp. 02-28-21
 STATE OF CALIFORNIA

OWNER ADDRESS:
Concentra
 1619-1623 EDINGER AVE.
 SANTA ANA, CA 92705

CONTACT:
 LISA STEWART
 CONSTRUCTION MANAGER
 (661)481-1851

SCOPE:
 TENANT IMPROVEMENT
 AND OFFICE EXPANSION

NOTES/REVISIONS:

PROJECT DATA:

DATE:	04-22-2020
ARCHITECT:	EM
CHECKED BY:	EM
DRAWN BY:	EM
PROJECT NO.:	1906
SCALE:	1" = 10'-0"

SHEET NAME/NUMBER:
 CUP PLOT PLAN
A-1.0

EXHIBIT 6

REQUEST FOR Planning Commission Action



PLANNING COMMISSION MEETING DATE:

AUGUST 24, 2020

TITLE:

PUBLIC HEARING – CONDITIONAL USE PERMIT NO. 2020-17 AND VARIANCE NO. 2020-03 TO FACILITATE THE EXPANSION OF AN EXISTING INDUSTRIAL MEDICAL CLINIC LOCATED AT 1619 EAST EDINGER AVENUE INTO TWO ADJACENT TENANT SPACES AT 1621 AND 1623 EAST EDINGER AVENUE – EDWIN MOHABIR, APPLICANT

PLANNING COMMISSION SECRETARY

APPROVED

- As Recommended
- As Amended
- Set Public Hearing For _____

DENIED

- Applicant's Request
- Staff Recommendation

Prepared by Jerry C. Guevara

Executive Director

CONTINUED TO _____

Planning Manager

RECOMMENDED ACTION

1. Adopt a resolution approving Conditional Use Permit No. 2020-17 as conditioned to allow the expansion of an existing industrial medical clinic; and
2. Adopt a resolution approving Variance No. 2020-03 as conditioned to allow a reduction in required off-street parking.

Executive Summary

Edwin Mohabir, representing Concentra Health Services, Inc., is requesting approval of Conditional Use Permit (CUP) No. 2020-17 and Variance No. 2020-03 to facilitate the expansion of an existing industrial medical clinic located at 1619 East Edinger Avenue into two adjacent tenant spaces located at 1621 and 1623 East Edinger Avenue. Staff is recommending approval of the entitlements as the proposed expansion will continue to provide services to the community and will not negatively impact surrounding land uses as conditions of approval will minimize impacts to the adjacent businesses and properties.

Table 1: Project and Location Information

Item	Information	
Project Address	1619, 1621 and 1623 East Edinger Avenue	
Nearest Intersection	Edinger Avenue and Lyon Street	
General Plan Designation	Industrial (IND)	
Zoning Designation	Light Industrial (M1)	
Surrounding Land Uses	North	Commercial / Industrial
	East	Commercial / Industrial
	South	Commercial / Industrial
	West	Commercial / Industrial
Property Size	0.66 acres	

Item	Information	
Existing Site Development	The site is currently developed with a 12,800-square foot multi-tenant commercial and industrial building, parking, and landscaping.	
Use Permissions	Allowed with a conditional use permit (CUP)	
Zoning Code Sections Affected	Use & Operational Standards	Sections 41-472.5(j) and 41-473 of SAMC
	Parking Requirements	Section 41-1346 of the SAMC

Project Description

The applicant is requesting approval of CUP No. 2020-17 and VA No. 2020-03 to facilitate the expansion of an existing industrial medical clinic located at 1619 East Edinger Avenue into two adjacent tenant spaces located at 1621 and 1623 East Edinger Avenue. As part of this application, the applicant is proposing to conduct tenant improvements consisting of partitions walls to create new exam, lab and break rooms, and new ADA compliant restrooms. In addition, the applicant will be restriping the parking lot to comply with ADA requirements, constructing a new trash enclosure to comply with current standards, and installing new landscaping along Edinger Avenue.

The proposed facility will have a total of 27 employees and is expected to serve two to three patients per hour, up to 24 to 33 patients per day. Hours of operation for the urgent care are 24 hours per day, seven days a week. Physical therapy is provided Monday through Friday from 7:00 a.m. to 6:00 p.m. The primary entrance to the facility will be through an entrance at the front of the building facing Edinger Avenue. Parking for patrons and employees will be provided through 40 surface parking spaces onsite.

Project Background and Chronology

The existing 12,800-square foot building was constructed in 1969 as a multi-tenant commercial and industrial building and has been occupied by a variety of office and industrial tenants over the years. In 2002, U.S. Healthworks began occupying 1619 East Edinger Avenue. In 2018, U.S. Healthworks was acquired by Concentra Health Services, Inc. On November 22, 2019, the City received a Development Project (DP) application on behalf of Concentra to expand its operations into 1621 and 1623 East Edinger Avenue. Since then, staff and the applicant have been working together to address current zoning, Building Division, and Public Works Agency requirements.

Concentra is a national health care company focused on improving the health of America's workforce. It provides occupational medicine, urgent care, physical therapy, and wellness services from more than 520 medical centers in 44 states. In addition to these medical center locations, Concentra serves employers by providing a broad range of health services by operating more than 140 medical facilities.

Project Analysis

Conditional Use Permit for Industrial Medical Clinic

The applicant is requesting approval of a CUP to allow the expansion of an existing industrial medical clinic. Pursuant to Santa Ana Municipal Code (SAMC) Section 41-472(j), an industrial medical clinic within the Light Industrial (M1) zoning district requires review and approval of a CUP

by the Planning Commission. CUP requests are governed by Section 41-638 of the SAMC. CUPs may be granted when it can be shown that the proposed project will not adversely impact the community. If these findings can be made, then it is appropriate to grant the CUP. Conversely, the inability to make these findings would result in a denial.

Staff has reviewed the applicant's request for the expansion of the existing industrial medical clinic and has determined that the use at the subject location will not be detrimental to the health, safety, and welfare of the surrounding community. The industrial medical clinic will not adversely affect the General Plan. The project is located within the Industrial (IND) General Plan land use designation, which plays a vital component to the city's economic health. These areas provide employment opportunities for local residents, and generate municipal revenues for continued economic. Typical uses found in this district include light and heavy product manufacturing and assembly and commercial uses which are ancillary to industrial uses in the district, such as industrial medical clinics.

Approval of the CUP will be consistent with several goals and policies of the General Plan. Policy 2.2 of the Land Use Element encourages land uses that accommodate the City's needs for goods and services. Furthermore Goal 1 of the Public Facilities Element promotes the need for sufficient public, cultural, recreational, educational, social service and related facilities to meet the community's needs. The industrial medical clinic will continue to provide a service to Santa Ana residents and workers.

Variance for Off-Street Parking

The applicant is requesting approval of a variance application to allow a reduction in required off-street parking. Pursuant to Section 41-1346 of the SAMC, medical clinics are required to be parked at the rate of five spaces for each 1,000 square feet of gross floor area. In addition, per SAMC Section 41-1390, manufacturing uses required two spaces per 1,000 square feet of production area. Based on this ratio, 48 parking spaces are required for the industrial medical clinic and six parking spaces are required for the operation of the adjacent manufacturing use (located at 1625 East Edinger Avenue) for a total of 54 on-site parking spaces. The applicant is proposing to provide 40 parking spaces on-site, which is 26 percent less than the required parking.

Table 2: Off-Street Parking

Land Use	Address	SAMC Requirement	Square Footage	Required
Industrial Medical Clinic	1619	5 spaces per 1,000 sq. ft. of gross floor area	3, 200 sq. ft.	48 spaces
	1621		3, 200 sq. ft.	
	1623		3, 200 sq. ft.	
Manufacturing Business	1625 E. Edinger Ave	2 spaces per 1,000 sq. ft. of gross production area	3,200 sq. ft.	6
			Total Required	54 spaces
			Total Provided	40 spaces
			Deficiency	14 spaces (26% Reduction)

Pursuant to Section 41-632 (a) (2) of the SAMC, the Planning Commission may grant a variance for a reduction in required parking if the reduction exceeds 20-percent of the minimum requirement and when it can be shown that there exists a special circumstance related to the property, it is necessary for the preservation and enjoyment of one or more substantial property rights, it will not be materially detrimental to the public welfare or injurious to surrounding property, and it will not adversely affect the General Plan of the City.

Staff has prepared the following analysis that forms the basis for the variance recommendation contained in this report. To determine whether or not the proposed parking spaces will be adequate to support the operations of the proposed industrial medical clinic and the adjacent manufacturing business, a Parking Demand Analysis was prepared by Overland Traffic Consultants, Inc., a traffic and transportation engineering firm (Exhibit 8). The study used the Institute of Transportation Engineer’s parking demand to determine the parking demand of both uses on-site and determined that a peak demand of 37 parking spaced would be needed for the combined land uses. The peak demand has been determined to occur from 9:00 a.m. to 10:00 a.m., 12:00 p.m. to 2:00 p.m. and from 6:00 p.m. to 7:00 p.m. Based on the results of the parking analysis, a surplus of three parking spaces will be provided on-site, with the existing 40 parking stalls sufficient to meet the demand of both uses. Furthermore, the project site is located in transit-friendly environment with transit, bicycling and walking amenities that facilitate and encourage alternative modes of transportation, further contributing to a reduction in parking demand. The nearest bus stop is located at the intersection of Edinger Avenue and Lyon Street. No additional traffic congestion is anticipated from the proposed facility. As part of the development process, the Public Works Agency reviewed the project and did not identify the need for any traffic mitigations. In addition, conditions of approval have been added to the variance to limit the number of participants on-site at one time. The variance will not be materially detrimental to the public welfare or injurious to surrounding properties.

Table 3: California Environmental Quality Act, Public Notification & Community Outreach

CEQA, Strategic Plan Alignment, Public Notification & Community Outreach	
CEQA	
CEQA Type	Categorically Exempt per Section 15301 (Class 1 – Existing Facilities) of the CEQA Guidelines
Document Type	Notice of Exemption, Environmental Review No. 2019-110
Reason(s) Exempt or Analysis	This exemption applies to the operation, licensing or minor alteration of private structures, involving no negligible or no expansion of existing or former use. The existing building is 12,800-square feet in floor area within M1 zone which allow the proposed use. Only minor interior and exterior improvements are being proposed and the proposed use is consistent with the former uses on-site.
Public Notification & Community Outreach	
Required Measures	A public notice was posted on the project site on August 14, 2020.
	Notification by mail was sent to all property owners and occupants within 500 feet of the project site on August 14, 2020.
	Newspaper posting was published in the Orange County Reporter on August 14, 2020.

Economic Development Benefits

The project will generate permit fees, temporary jobs, permanent jobs and needed services for the community. The improvements for the project will require permit fees ranging from \$10,000 to \$15,000 paid to the City and will result in temporary construction jobs. It is estimated that five to seven new job opportunities will be created with the operation of the facility and approximately \$600 annually will be paid in business taxes.

Conclusion

Based on the analysis provided within this report, staff recommends that the Planning Commission approve Conditional Use Permit No. 2020-17 and Variance No. 2020-03 as conditioned.

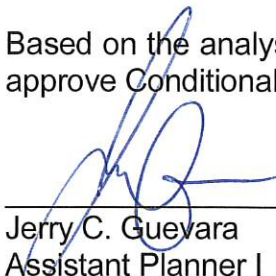

Jerry C. Guevara
Assistant Planner I

JG:S:\Planning Commission\2020\08-24-20\CUP No. 2020-17 & VA No. 2020-03 for Cocentra at 1619 E. Edinger Ave\CUP No. 2020-17 & VA No. 2020-03 for Concentra.RFPCA.doc

- Exhibits:
- 1 – CUP No. 2020-17 Resolution
 - 2 – VA No. 2020-03 Resolution
 - 3 – Vicinity Zoning & Aerial View
 - 4 – Site Photo
 - 5 – Site Plan
 - 6 – Floor Plan
 - 7 – Landscape Plan
 - 8 – Parking Demand Study

EXHIBIT 1

12-87

RESOLUTION NO. 2020-xx

A RESOLUTION OF THE PLANNING COMMISSION OF THE CITY OF SANTA ANA APPROVING CONDITIONAL USE PERMIT NO. 2020-17 AS CONDITIONED TO ALLOW THE EXPANSION OF AN EXISTING INDUSTRIAL MEDICAL CLINIC LOCATED AT 1619 EAST EDINGER AVENUE INTO TWO ADJACENT TENANT SPACES LOCATED AT 1621 AND 1623 EAST EDINGER AVENUE

BE IT RESOLVED BY THE PLANNING COMMISSION OF THE CITY OF SANTA ANA AS FOLLOWS:

Section 1. The Planning Commission of the City of Santa Ana hereby finds, determines and declares as follows:

- A. Edwin Mohabir, representing Concentra Health Services, Inc. ("Applicant"), is requesting approval of Conditional Use Permit (CUP) No. 2020-17 to allow the expansion of an existing 3,200-square industrial medical clinic located at 1619 East Edinger Avenue into two adjacent tenant spaces located at 1621 and 1623 East Edinger Avenue. The total floor area of the entire completed facility will be 9,600 square feet.
- B. Pursuant to Santa Ana Municipal Code (SAMC) Section 41-472.5(j), industrial medical clinics within the Light Industrial (M1) zoning district require approval of a CUP.
- C. Pursuant to SAMC Section 41-638, the Planning Commission is authorized to review and approve the CUP for this project as set forth by the SAMC.
- D. On August 24, 2020, the Planning Commission held a duly noticed public hearing for CUP No. 2020-17.
- E. The Planning Commission of the City of Santa Ana has considered the information and determines that the following findings, which must be established in order to grant CUP No. 2020-17, for an industrial medical clinic, have been established as required by SAMC Section 41-638:
 1. That the proposed use will provide a service or facility which will contribute to the general well being of the neighborhood or community.

The proposed expansion of an existing industrial medical clinic will provide a service to persons and families that are working or residing in the area. The clinic will provide a benefit to the community by providing needed services to the targeted

population. Concentra provides occupational health, physical therapy, and urgent cares services.

2. That the proposed use will not, under the circumstances of the particular case, be detrimental to the health, safety, or general welfare of persons residing or working in the vicinity.

The proposed expansion of the existing industrial medical clinic will not be detrimental to the health, safety or welfare of those residing or working in the vicinity. The facility will be operated within an existing commercial and industrial building and the proposed expansion and its operations are compatible with nearby commercial and industrial uses. Impacts are not anticipated from the project.

3. That the proposed use will not adversely affect the present economic stability or future economic development of properties surrounding the area.

The industrial medical clinic will not adversely affect the economic stability or future economic development of properties in the surrounding area. The proposed industrial medical clinic expansion will occupy a vacant tenant space which will help re-establish economic use of the property and help activate the industrial center. The project also includes exterior improvement investments that will improve the appearance and economic stability of the area.

4. That the proposed use will comply with the regulations and conditions specified in Chapter 41 for such use.

The proposed use complies with the regulations and conditions in Chapter 41 (Zoning) of the SAMC. As part of this application, the Applicant is proposing to conduct exterior and interior improvements to the site. The M1 zoning district allows for industrial medical clinics subject to a conditional use permit. The use is similar in nature to other uses that are permitted within the M1 zoning district. A condition of approval has been added to require front yard landscaping and a property maintenance agreement to be recorded against the property which will ensure that the property and all improvements are properly maintained.

5. That the proposed use will not adversely affect the General Plan of the city or any specific plan applicable to the area of the proposed use.

The expanded industrial medical clinic will not adversely affect the General Plan. The project is located within the Industrial (IND) General Plan land use designation which plays a vital

component to the city's economic health. These areas provide employment opportunities for local residents, and generate municipal revenues for continued economic growth. Typical uses found in this district include light and heavy product manufacturing and assembly and commercial uses which are ancillary to industrial uses in the district. Approval of the CUP will be consistent with several goals and policies of the General Plan. Policy 2.2 of the Land Use Element encourages land uses that accommodate the City's needs for goods and services, and Policy 5.5 encourages development that is compatible with and supporting of surrounding land uses. The proposed industrial medical clinic expansion will continue to allow Concentra to provide needed services to the City's residents and workers.

Section 2. In accordance with the California Environmental Quality Act (CEQA) and the CEQA Guidelines, the project is categorically exempt from further review per Section 15301 (Class 1 – Existing Facilities) of the CEQA Guidelines. The Class 1 exemption applies to the operation, repair, maintenance, permitting, leasing, licensing, or minor alteration of existing private structures involving negligible or no expansion of the use. The existing 12,800-square foot building is within the M1 zone which allows for such use. The proposed industrial medical clinic does not involve an expansion in use since the building has been utilized by similar industrial medical clinic uses in the past. As a result, Categorical Exemption, Environmental Review No. 2019-110 will be filed for this project.

Section 3. The Applicant shall indemnify, protect, defend and hold the City and/or any of its officials, officers, employees, agents, departments, agencies, authorized volunteers, and instrumentalities thereof, harmless from any and all claims, demands, lawsuits, writs of mandamus, referendum, and other proceedings (whether legal, equitable, declaratory, administrative or adjudicatory in nature), and alternative dispute resolution procedures (including, but not limited to arbitrations, mediations, and such other procedures), judgments, orders, and decisions (collectively "Actions"), brought against the City and/or any of its officials, officers, employees, agents, departments, agencies, and instrumentalities thereof, that challenge, attack, or seek to modify, set aside, void, or annul, any action of, or any permit or approval issued by the City and/or any of its officials, officers, employees, agents, departments, agencies, and instrumentalities thereof (including actions approved by the voters of the City) for or concerning the project, whether such Actions are brought under the Ralph M. Brown Act, California Environmental Quality Act, the Planning and Zoning Law, the Subdivision Map Act, Code of Civil Procedure sections 1085 or 1094.5, or any other federal, state or local constitution, statute, law, ordinance, charter, rule, regulation, or any decision of a court of competent jurisdiction. It is expressly agreed that the City shall have the right to approve, which approval will not be unreasonably withheld, the legal counsel providing the City's defense, and that Applicant shall reimburse the City for any costs and expenses directly and necessarily incurred by the City in the course of the defense. City shall promptly notify the Applicant of any Action brought and City shall cooperate with Applicant in the defense of the Action.

Section 4. Conditional Use Permit No. 2020-17 shall not be effective unless and until the Planning Commission reviews and approves Variance No. 2020-03. If said approvals are held to be invalid or unconstitutional by the decision of any court of competent jurisdiction, or otherwise denied, then this conditional use permit shall be null and void and have no further force and effect.

Section 5. The Planning Commission of the City of Santa Ana after conducting the public hearing hereby approves CUP No. 2020-17, as conditioned in Exhibit A, attached hereto and incorporated herein for the project located at 1619, 1621 and 1623 East Edinger Avenue. This decision is based upon the evidence submitted at the abovesaid hearing, which includes, but is not limited to: the Request for Planning Commission Action dated August 24, 2020, and exhibits attached thereto; and the public testimony, written and oral, all of which are incorporated herein by this reference.

ADOPTED this 24th day of August, 2020.

AYES: Commissioners:
NOES: Commissioners:
ABSENT: Commissioners:
ABSTENTIONS: Commissioners:

Mark McLoughlin
Chairperson

APPROVED AS TO FORM:
Sonia R. Carvalho, City Attorney

By: _____
Lisa Storck
Assistant City Attorney

CERTIFICATE OF ATTESTATION AND ORIGINALITY

I, SARAH BERNAL, Recording Secretary, do hereby attest to and certify the attached Resolution No. 2020-XX to be the original resolution adopted by the Planning Commission of the City of Santa Ana on August 24, 2020.

Date: _____

Recording Secretary
City of Santa Ana

EXHIBIT A

Conditions of Approval for Conditional Use Permit No. 2020-17

Conditional Use Permit No. 2020-17 for an industrial medical clinic use is approved subject to compliance, to the reasonable satisfaction of the Executive Director of the Planning and Building Agency, with applicable sections of the Santa Ana Municipal Code, the California Administrative Code, the California Building Standards Code, and all other applicable regulations. In addition, the following conditions of approval shall be met:

The Applicant must comply with each and every condition listed below prior to exercising the rights conferred by this conditional use permit.

1. All proposed site improvements must conform to the Development Project Review (DP No. 2019-45) and the staff report exhibits are incorporated herein by reference.
2. Any amendment to this conditional use permit must be submitted to the Planning Division for review. At that time, staff will determine if administrative relief is available or if the conditional use permit must be amended.
3. The operation of the industrial medical clinic is also subject to Variance No. 2020-03, as conditioned.
4. Prior to the issuance of a Building Permit, the Applicant shall submit a landscape and irrigation plan to the Planning Division for review and approval. The landscape and irrigation shall comply with the zoning district's landscape standards, the Water Efficient Landscape Ordinance (WELO), and the Citywide Design Guidelines.
5. Prior to the issuance of a Building Permit, a Property Maintenance Agreement must be recorded against the property. The agreement will be subject to review and applicability by the Planning and Building Agency, the Community Development Agency, the Public Works Agency, and the City Attorney to ensure that the property and all improvements located thereupon are properly maintained, Developer/Applicant (and the owner of the property upon which the authorized use and/or authorized improvements are located if different from the Applicant) shall execute a Maintenance Agreement with the City of Santa Ana which shall be recorded against the property and which shall be in a form reasonably satisfactory to the City Attorney. The Maintenance Agreement shall contain covenants, conditions and restrictions relating to the following:
 - a. Compliance with operational conditions applicable during any period(s) of construction or major repair (e.g., proper screening and securing of the construction site; implementation of proper erosion control, dust control and noise mitigation; adherence to approved project phasing etc.), if applicable;

- b. Compliance with ongoing operational conditions, requirements and restrictions, as applicable (including but not limited to hours of operation, security requirements, the proper storage and disposal of trash and debris, enforcement of the parking management plan, and/or restrictions on certain uses) if applicable;
- c. Ongoing compliance with approved design and construction parameters, signage parameters and restrictions as well as landscape designs, as applicable;
- d. Ongoing maintenance, repair and upkeep of the property and all improvements located thereupon (including but not limited to controls on the proliferation of trash and debris about the property; the proper and timely removal of graffiti; the timely maintenance, repair and upkeep of damaged, vandalized and/or weathered buildings, structures and/or improvements; the timely maintenance, repair and upkeep of exterior paint, parking striping, lighting and irrigation fixtures, walls and fencing, publicly accessible bathrooms and bathroom fixtures, landscaping and related landscape improvements and the like, as applicable;
- e. If Developer/Applicant and the owner of the property are different (e.g., if the Applicant is a tenant or licensee of the property or any portion thereof), both the Applicant and the owner of the property shall be signatories to the Maintenance Agreement and both shall be jointly and severally liable for compliance with its terms;
- f. The Maintenance Agreement shall further provide that any party responsible for complying with its terms shall not assign its ownership interest in the property or any interest in any lease, sublease, license or sublicense, unless the prospective assignee agrees in writing to assume all of the duties, obligations and responsibilities set forth under the Maintenance Agreement; and
- g. The Maintenance Agreement shall contain provisions relating to the enforcement of its conditions by the City and shall also contain provisions authorizing the City to recover costs and expenses which the City may incur arising out of any enforcement and/or remediation efforts which the City may undertake in order to cure any deficiency in maintenance, repair or upkeep or to enforce any restrictions or conditions upon the use of the property. The maintenance agreement shall further provide that any unreimbursed costs and/or expenses incurred by the City to cure a deficiency in maintenance or to enforce use restrictions shall become a lien upon the property in an amount equivalent to the actual costs and/or expense incurred by the City.

EXHIBIT 2

12-131

RESOLUTION NO. 2020-xx

A RESOLUTION OF THE PLANNING COMMISSION OF THE CITY OF SANTA ANA APPROVING VARIANCE NO. 2020-03 AS CONDITIONED ALLOWING A REDUCTION IN REQUIRED OFF-STREET PARKING TO FACILITATE EXPANSION OF AN EXISTING INDUSTRIAL MEDICAL CLINIC LOCATED AT 1619, 1621 AND 1623 EAST EDINGER AVENUE

BE IT RESOLVED BY THE PLANNING COMMISSION OF THE CITY OF SANTA ANA AS FOLLOWS:

Section 1. The Planning Commission of the City of Santa Ana hereby finds, determines and declares as follows:

- A. Edwin Mohabir, representing Concentra Health Services, Inc. ("Applicant"), is requesting approval of Variance (VA) No. 2020-03 to allow a reduction in required off-street parking for an industrial medical clinic located at 1619, 1621 and 1623 East Edinger Avenue.
- B. Pursuant to Santa Ana Municipal Code (SAMC) Section 41-1346, medical clinics are required to provide on-site parking at a rate of five spaces per 1,000 square feet of gross floor area. Based on this ratio, 54 parking spaces are required for the proposed industrial medical clinic and existing manufacturing use on-site. The Applicant is proposing to provide 40 parking spaces on-site, 26 percent less than the required on-site parking, therefore, requiring approval of a variance.
- C. Pursuant to SAMC 41-632, the Planning Commission is authorized to review and approve a variance for a reduction in off-street parking for the subject property and project as set forth by the SAMC.
- D. On August 24, 2020, the Planning Commission held a duly noticed public hearing for VA No. 2020-03.
- E. The Planning Commission of the City of Santa Ana has considered the information and determines that the following findings, which must be established in order to grant VA No. 2020-03, for a reduction in required off-street parking, have been established as required by SAMC section 41-638:
 1. That because of special circumstances applicable to the subject property, including size, shape, topography, location or surroundings, the strict application of the zoning ordinance is found to deprive the subject property of privileges not otherwise at

variance with the intent and purpose of the provisions of this Chapter.

There are special circumstances related to the existing conditions of the property. In 1969, the building and site improvements were constructed which included a 12,800-square foot building. In order to meet the City's current off-street parking requirements for an industrial medical clinic, significant modifications to the building and site, such as demolishing portions of the building, would be required. Strict application of the off-street parking regulations would not allow the tenant to expand its operations and services to its customers. The parking analysis conducted by Overland Traffic Consultants, Inc., supports the intent of the code which is to provide sufficient off-street parking. The study indicates that there would be sufficient parking for the proposed use, therefore, no parking impacts to the nearby uses or properties will be created.

2. That the granting of a variance is necessary for the preservation and enjoyment of one (1) or more substantial property rights.

Granting this variance is necessary for the preservation and enjoyment of substantial property rights. Granting this variance will allow the property to continue and expand its use as an industrial medical clinic which will benefit the community at large. The use is compatible with surrounding land uses and will not be detrimental to the surrounding community.

3. That the granting of a variance will not be materially detrimental to the public welfare or injurious to surrounding property.

Granting this variance will not be detrimental to the public or surrounding properties. A parking analysis was conducted which concluded that a peak demand of 37 parking spaces would be needed for the combined land uses on-site. The peak demand has been determined to occur from 9:00 a.m. to 10:00 a.m., 12:00 p.m. to 2:00 p.m. and from 6:00 p.m. to 7:00 p.m. Based on the results of the parking analysis, a surplus of three (3) parking spaces will be provided on-site and the proposed 40 parking stalls are sufficient to meet the demand of both land uses. Furthermore, conditions of approval have been added to the variance which would mitigate, if there was any, impact to surrounding properties.

4. That the granting of a variance will not adversely affect the General Plan of the city.

The variance for a reduction in required off-street parking will not adversely affect the General Plan. The project is located within the Industrial (IND) General Plan land use designation which plays a vital component to the city's economic health. These areas provide employment opportunities for local residents, and generate municipal revenues for continued economic growth. Typical uses found in this district include light and heavy product manufacturing and assembly, and commercial uses which are ancillary to industrial uses in the district. Approval of the variance will be consistent with several goals and policies of the General Plan. The expanded industrial medical clinic will not adversely affect the General Plan. Policy 2.2 of the Land Use Element encourages land uses that accommodate the City's needs for goods and services and Policy 5.5 encourages development that is compatible with and supporting of surrounding land uses. The proposed industrial medical clinic expansion will continue to allow Concentra to provide needed services to the City's residents and workers.

Section 2. In accordance with the California Environmental Quality Act (CEQA) and the CEQA Guidelines, the project is categorically exempt from further review per Section 15301 (Class 1 – Existing Facilities) of the CEQA Guidelines. The Class 1 exemption applies to the operation, repair, maintenance, permitting, leasing, licensing, or minor alteration of existing private structures involving negligible or no expansion of the use. The existing 12,800-square foot building is within the M1 zone which allows for such use. The proposed industrial medical clinic does not involve an expansion in use since the building has been utilized by similar industrial medical clinic uses in the past. As a result, Categorical Exemption, Environmental Review No. 2019-110 will be filed for this project.

Section 3. The Applicant shall indemnify, protect, defend and hold the City and/or any of its officials, officers, employees, agents, departments, agencies, authorized volunteers, and instrumentalities thereof, harmless from any and all claims, demands, lawsuits, writs of mandamus, referendum, and other proceedings (whether legal, equitable, declaratory, administrative or adjudicatory in nature), and alternative dispute resolution procedures (including, but not limited to arbitrations, mediations, and such other procedures), judgments, orders, and decisions (collectively "Actions"), brought against the City and/or any of its officials, officers, employees, agents, departments, agencies, and instrumentalities thereof, that challenge, attack, or seek to modify, set aside, void, or annul, any action of, or any permit or approval issued by the City and/or any of its officials, officers, employees, agents, departments, agencies, and instrumentalities thereof (including actions approved by the voters of the City) for or concerning the project, whether such Actions are brought under the Ralph M. Brown Act, California Environmental Quality Act, the Planning and Zoning Law, the Subdivision Map Act, Code of Civil Procedure sections 1085 or 1094.5, or any other federal, state or local constitution, statute, law, ordinance, charter, rule, regulation, or any decision of a

court of competent jurisdiction. It is expressly agreed that the City shall have the right to approve, which approval will not be unreasonably withheld, the legal counsel providing the City's defense, and that Applicant shall reimburse the City for any costs and expenses directly and necessarily incurred by the City in the course of the defense. City shall promptly notify the Applicant of any Action brought and City shall cooperate with Applicant in the defense of the Action.

Section 4. Variance No. 2020-03 shall not be effective unless and until the Planning Commission reviews and approves Conditional Use Permit No. 2020-17. If said approvals are held to be invalid or unconstitutional by the decision of any court of competent jurisdiction, or otherwise denied, then this variance shall be null and void and have no further force and effect.

Section 5. The Planning Commission of the City of Santa Ana, after conducting the public hearing, hereby approves VA No. 2020-03 as conditioned in Exhibit A, attached hereto and incorporated as though fully set forth herein. This decision is based upon the evidence submitted at the above said hearing, which includes, but is not limited to: the Request for Planning Commission Action dated August 24, 2020, and exhibits attached thereto; and the public testimony, written and oral, all of which are incorporated herein by this reference.

ADOPTED this 24th day of August, 2020.

AYES: Commissioners:
NOES: Commissioners:
ABSENT: Commissioners:
ABSTENTIONS: Commissioners:

Mark McLoughlin
Chairperson

APPROVED AS TO FORM:
Sonia R. Carvalho, City Attorney

By: _____
Lisa E. Storck
Assistant City Attorney

CERTIFICATE OF ATTESTATION AND ORIGINALITY

I, SARAH BERNAL, Recording Secretary, do hereby attest to and certify the attached Resolution No. 2020-xx to be the original resolution adopted by the Planning Commission of the City of Santa Ana on August 24, 2020.

Date: _____

Recording Secretary
City of Santa Ana

EXHIBIT A

Conditions of Approval for Variance No. 2020-03

Variance No. 2020-03 is approved subject to compliance, to the reasonable satisfaction of the Planning Manager, with applicable sections of the Santa Ana Municipal Code, the California Administrative Code, the California Building Standards Code, and all other applicable regulations. In addition, the following conditions of approval shall be met:

The Applicant must comply with each and every condition listed below prior to exercising the rights conferred by this variance.

1. All proposed site improvements must conform to the Development Project Review (DP No. 2019-45) and the staff report exhibits are incorporated herein by reference.
2. Any amendment to this variance must be submitted to the Planning Division for review. At that time, staff will determine if administrative relief is available or if the variance must be amended.
3. The operation of the industrial medical clinic is also subject to Conditional Use Permit No. 2020-17, as conditioned.
4. Prior to the issuance of a Building Permit, the Applicant shall submit a landscape and irrigation plan to the Planning Division for review and approval. The landscape and irrigation shall comply with the zoning district's landscape standards, the Water Efficient Landscape Ordinance (WELO), and the Citywide Design Guidelines.
5. Prior to the issuance of a Building Permit, a Property Maintenance Agreement must be recorded against the property. The agreement will be subject to review and applicability by the Planning and Building Agency, the Community Development Agency, the Public Works Agency, and the City Attorney to ensure that the property and all improvements located thereupon are properly maintained, Developer/Applicant (and the owner of the property upon which the authorized use and/or authorized improvements are located if different from the Applicant) shall execute a Maintenance Agreement with the City of Santa Ana which shall be recorded against the property and which shall be in a form reasonably satisfactory to the City Attorney. The Maintenance Agreement shall contain covenants, conditions and restrictions relating to the following:
 - a. Compliance with operational conditions applicable during any period(s) of construction or major repair (e.g., proper screening and securing of the construction site; implementation of proper erosion control, dust control and noise mitigation; adherence to approved project phasing etc.), if applicable;
 - b. Compliance with ongoing operational conditions, requirements and restrictions, as applicable (including but not limited to hours of operation, security requirements, the proper storage and disposal of trash and debris,

enforcement of the parking management plan, and/or restrictions on certain uses) if applicable;

- c. Ongoing compliance with approved design and construction parameters, signage parameters and restrictions as well as landscape designs, as applicable;
- d. Ongoing maintenance, repair and upkeep of the property and all improvements located thereupon (including but not limited to controls on the proliferation of trash and debris about the property; the proper and timely removal of graffiti; the timely maintenance, repair and upkeep of damaged, vandalized and/or weathered buildings, structures and/or improvements; the timely maintenance, repair and upkeep of exterior paint, parking striping, lighting and irrigation fixtures, walls and fencing, publicly accessible bathrooms and bathroom fixtures, landscaping and related landscape improvements and the like, as applicable;
- e. If Developer/Applicant and the owner of the property are different (e.g., if the Applicant is a tenant or licensee of the property or any portion thereof), both the Applicant and the owner of the property shall be signatories to the Maintenance Agreement and both shall be jointly and severally liable for compliance with its terms;
- f. The Maintenance Agreement shall further provide that any party responsible for complying with its terms shall not assign its ownership interest in the property or any interest in any lease, sublease, license or sublicense, unless the prospective assignee agrees in writing to assume all of the duties, obligations and responsibilities set forth under the Maintenance Agreement; and
- g. The Maintenance Agreement shall contain provisions relating to the enforcement of its conditions by the City and shall also contain provisions authorizing the City to recover costs and expenses which the City may incur arising out of any enforcement and/or remediation efforts which the City may undertake in order to cure any deficiency in maintenance, repair or upkeep or to enforce any restrictions or conditions upon the use of the property. The maintenance agreement shall further provide that any unreimbursed costs and/or expenses incurred by the City to cure a deficiency in maintenance or to enforce use restrictions shall become a lien upon the property in an amount equivalent to the actual costs and/or expense incurred by the City.

EXHIBIT 3

12-232

**CUP No. 2020-17 & VA No. 2020-03
1619, 1621 & 1623 E. Edinger Avenue**



Exhibit 3 - Vicinity Zoning & Aerial View



EXHIBIT 4

12-234

**CUP No. 2020-17 & VA No. 2020-03
1619, 1621 & 1623 E. Edinger Avenue**

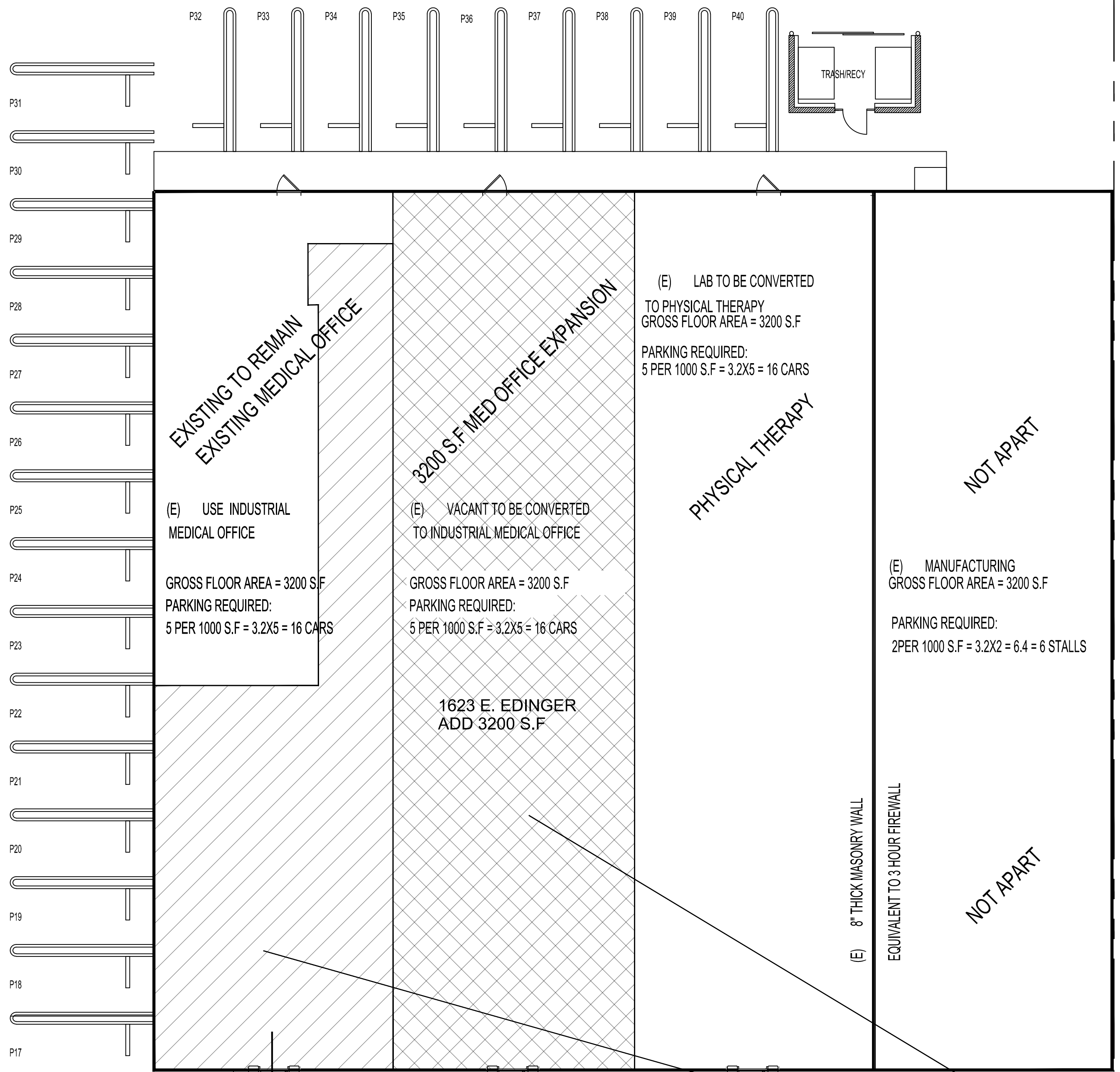

Exhibit 4 – Site Photo

EXHIBIT 5

12-236

PL COMMON DRIVEWAY



SUMMIT COLLEGE

ITEM # A6 - PARKING TABULATION

PARKING REQUIRED:	
1619 E. EDINGER	16 STALLS
1621 E. EDINGER	16 STALLS
1623 E. EDINGER	16 STALLS
1625 E. EDINGER	6 STALLS
TOTAL REQUIRED	54 STALLS
PARKING PROVIDED	40 STALLS
PARKING DEFICIT	14 STALLS
PERCENTAGE DEFICIT	26
VA REQUIRED	

PROJECT DATA

Project Address:
 1619 E. Edinger Ave
 1621 E. Edinger Ave
 1623 E. Edinger Ave
 APN: 402-241-10

Applicant:
 Edwin Mohabir (323)459-8809

General Plan Land Use Designation Light Industrial
 Allowable FAR ?
 Zoning M1
 Total Lot Area 33,839 square feet 0.78 ac.
 Existing medical office = 3200 square feet
 Proposed medical expansion = 3200 square feet
 Proposed Physical Therapy = 3200 square feet
 Existing Manufacturing = 3200 square feet
 Parking Tabulation:
 Gross floor area for all medical use = 9600 square feet
 Parking required 5 per 1000 s.f. = 48 stalls
 Manufacturing 2 per 1000 s.f. = 6.4 stalls
 Total parking required = 54 stalls
 Existing parking = 38 stalls
 Existing ADA complying stalls = 2 stalls
 Total provided = 40 stalls
 Occupancy Type:
 1619 E. Edinger Ave Group B Occupancy
 1621 E. Edinger Ave Group B Occupancy proposed
 1623 E. Edinger Ave Group B Occupancy proposed
 1625 E. Edinger Ave Group F1 Occupancy
 Construction type Type VB
 Exterior walls Masonry
 Roof Materials Panelized roof with wood beams and purlins
 Non Sprinklered Building
 Building Height = 15 ft.
 Allowable Building Height = 40 ft. per CBC Tbl. 504.3

There are no existing or proposed easements.
 There are no fence around the property.

APPLICABLE CODES:
 2019 California Building Code (CBC)
 2019 California Residential Code (CRC)
 2019 California Mechanical Code
 2019 California Plumbing Code
 2019 California Electrical Code
 2019 California Energy Code
 2019 California Green Standards Code (CALGreen)
 Santa Ana Municipal Code (SAMCU)

SHEET INDEX:

A-1.0	CUP PLOT PLAN
A-1.01	DEVELOPMENT REVIEW APPROVAL
A-1.1	SITE PLAN
A-1.2	PARKING CALCULATIONS
A-1.3	AREA CALCULATIONS
A-2.0	EXITING FLOOR PLAN
A-2.1	PROPOSED FLOOR PLAN
A-2.2	OCCUPANT LOAD AND EXITING PLAN
C-1	COVER SHEET
C-2	SITE GRADING PLAN
C-3	UTILITY PLAN
L-1	PLANTING PLAN
L-2	IRRIGATION PLAN
L-3	DETAILS
L-4	DETAILS
L-5	DETAILS
L-6	NOTES

LEGEND

--- POT: ACCESSIBLE PATH OF TRAVEL AS INDICATED ON PLAN IS A BARRIER FREE ACCESS ROUTE WITHOUT ANY ABRUPT LEVEL CHANGES EXCEEDING 1/2" IF BEVEL AT 1:2 MAX. SLOPE, OR VERTICAL LEVEL CHANGES NOT EXCEEDING 1/4" AND AT LEAST 48" IN WIDTH. THE SURFACE IS STABLE, FIRM, AND SLIP RESISTANT. CROSS SLOPE DOES NOT EXCEED 2% AND SLOPE IN THE DIRECTION OF TRAVEL IS LESS THAN 5% SLOPE, UNLESS OTHERWISE INDICATED. LANDING AT DOORWAYS SHALL BE 2% MAX.

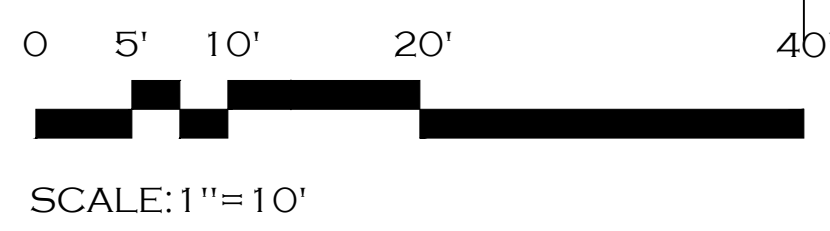

COMMON DRIVEWAY

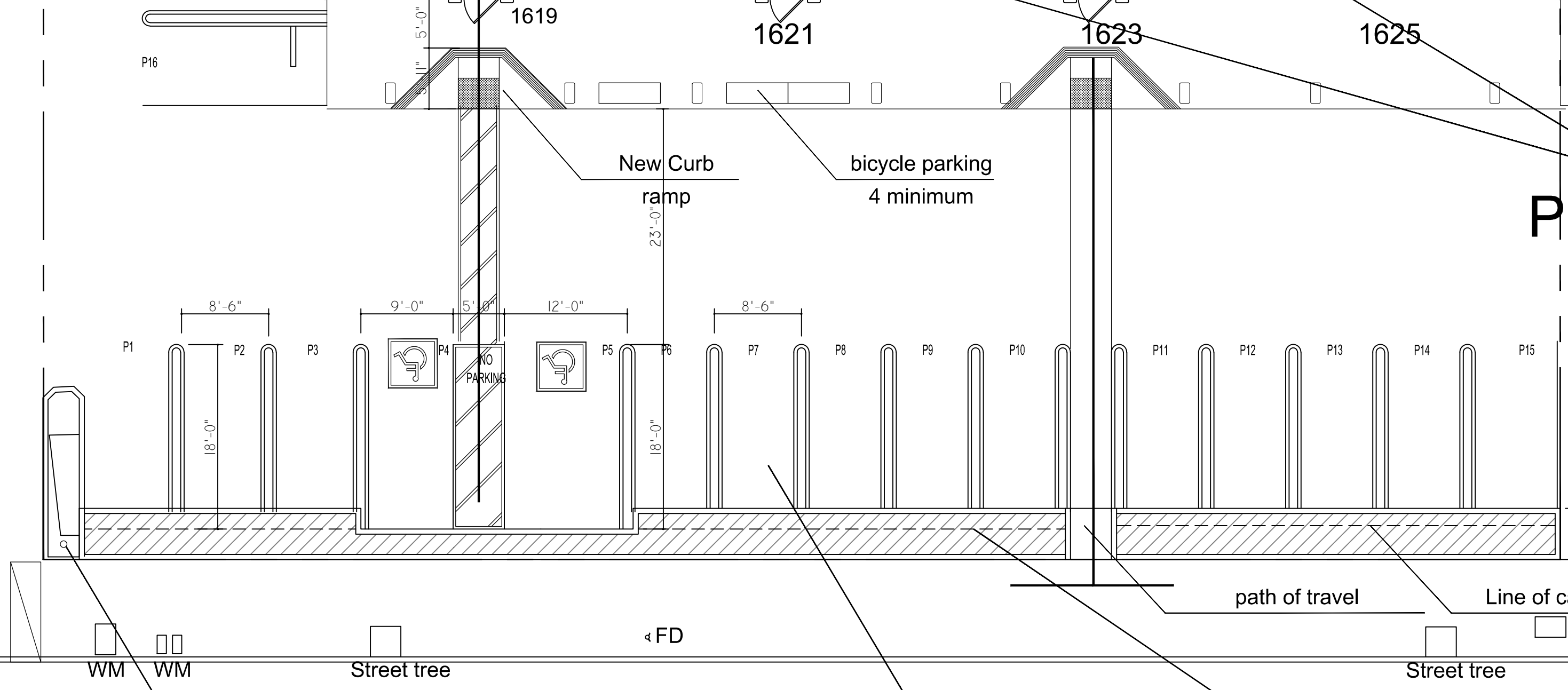

ITEM # A4
 NON CONFORMING POLE SIGN TO BE REMOVED. MONUMENT SIGN IF DESIRED MUST COMPLY TO SECTION 41-862 OF THE SAMC.

ITEM # A1
 PARKING LOT RE-STRIPE PER SANTA ANA CITY STDS

ITEM # A2 & 3
 5' LANDSCAPE SEE LANDSCAPE PLANS

EDWIN MOHABIR
EM
 ARCHITECT, INC.
 SANTA CLARITA, CA 91381
 24979 CONSTITUTION AVE. #1435
 EDWINMOHABIR@GMAIL.COM
 TEL: 323-459-8809

OWNER/ADDRESS:
Concentra
 1619-1623 EDINGER AVE.
 SANTA ANA, CA 92705

CONTACT:
 LISA STEWART
 CONSTRUCTION MANAGER
 (661)481-1851

SCOPE:
 TENANT IMPROVEMENT
 AND OFFICE EXPANSION

NOTES/REVISIONS:

PROJECT DATA:

DATE:	07-14-2020
ARCHITECT:	EM
CHECKED BY:	EM
DRAWN BY:	EM
PROJECT NO.:	1906
SCALE:	1" = 10'-0"

SHEET NAME/NUMBER:
 CUP PLOT PLAN
A-1.0

EXHIBIT 6

12-258

DOOR SCHEDULE

DOOR & FRAME SCHEDULE											
NO.	SIZE	DOOR				FRAME				HARDWARE	FIRE RATINGS & ETC.
		TYPE	MAT.	CORE	FINISH	TYPE	MAT.	FINISH			
1	36"x84"x1-3/4"	A	W	SC	PL	-	-	HM	AL	LS, CL	OFFICE (EXAM/TREATMENT)/ CONFERENCE-STORAGE
2	36"x84"x1-3/4"	A	W	SC	PL	-	-	HM	AL	LPBRS, CL	BREAK ROOM/ RESTROOMS
3	36"x84"x1-3/4"	A	W	SC	PL	T	-	HM	AL	PB, CL	HALLWAY
4	36"x84"x1-3/4"	A	HM	HM	PL	-	-	HM	AL	PB, MAGNETIC HOLD OPEN	90 MIN FIRE RATED

NOTE:
 SINGLE INTERIOR DOOR: 3'-0" X 8'-0" X 1 3/4" SOLID COOR, PLASTIC LAMINATE DOOR/PLASTIC LAMINATE TO BE: FORMICA #208-1X GLACIUR CHERRY (LUXE FINISH, TO MATCH EXISTING).
 SINGLE RATED INTERIOR DOOR: 3'-0" X 8'-0" X 1 3/4" 20 MIN RATING. BUILDING STANDARD DOOR.
 SINGLE INTERIOR DOOR: 3'-0" X 8'-0" X 1 3/4" SOLID COOR, PLASTIC LAMINATE DOOR W/ INTRAGAL FRAMED SIDELIGHT (MAX WIDTH).
 1. ALL DOORS TO BE UNDERCUT TO CLEAR FINISH COVERHANG AND/OR THRESHOLD BY 2" UNLESS OTHERWISE NOTED.
 2. ALL DOOR FRAMES TO BE: "WESTERN INTEGRATED" 1 1/2" PROFILE, CLEAR ANODIZED ALUMINUM FINISH.
 3. PROVIDE FLOOR DOOR STOPS: IVES DOME STOP, (OR EQ)

LEGEND					
AL	ANODIZED ALUMINUM	HM	HOLLOW METAL	PB	PANIC BAR
BB	BALL BEARING BOLTS	IN	INSULATED	PRE	PRE FINISHED
C	CHAIN	LPBRS	LEVER PRIVACY SET	PT	PAINT
CL	CLOSER	LS	LOCK SET	SC	SOLID CORE
DB	DEAD BOLT	NRP	NON REMOVABLE PIN	ST	STAIN
GL	GLAZING	PL	PLASTIC LAMINATE	ST	STOP
				T	TEMPERED
				TH	ALUMINUM THRESHOLD
				W	WOOD
				WS	WEATHERSTRIPPING
				E	EXISTING DOOR TO REMAIN

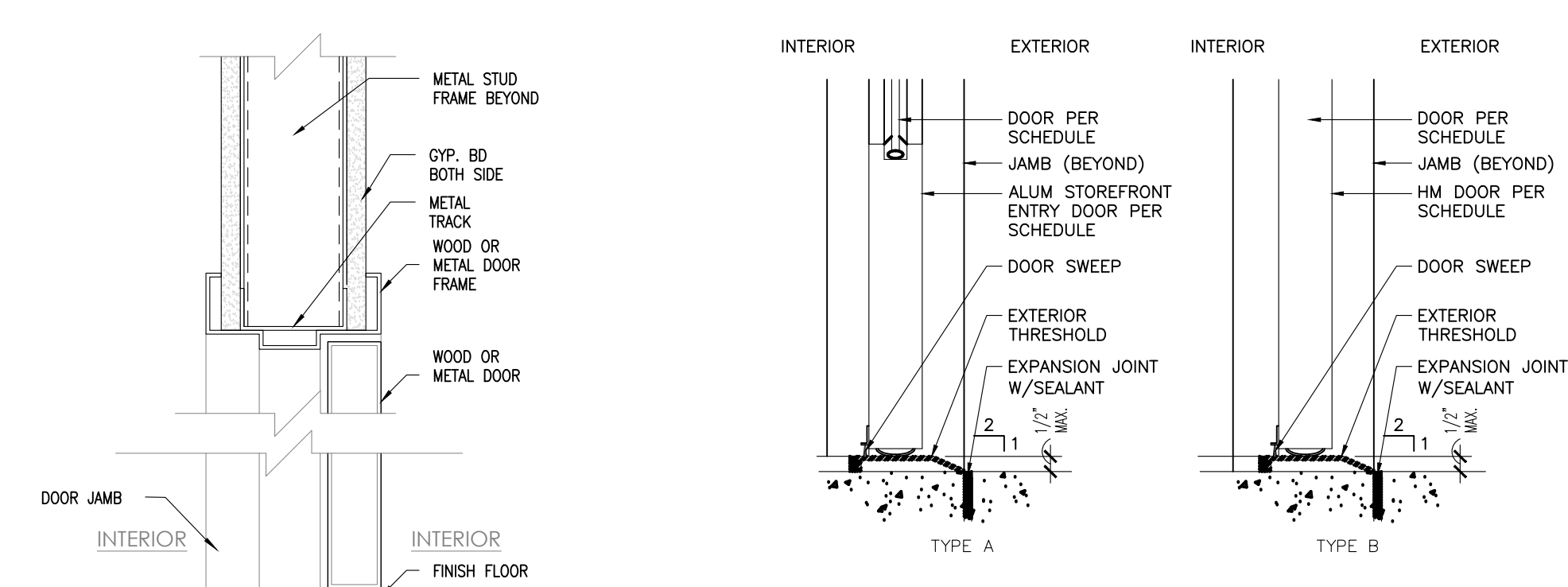
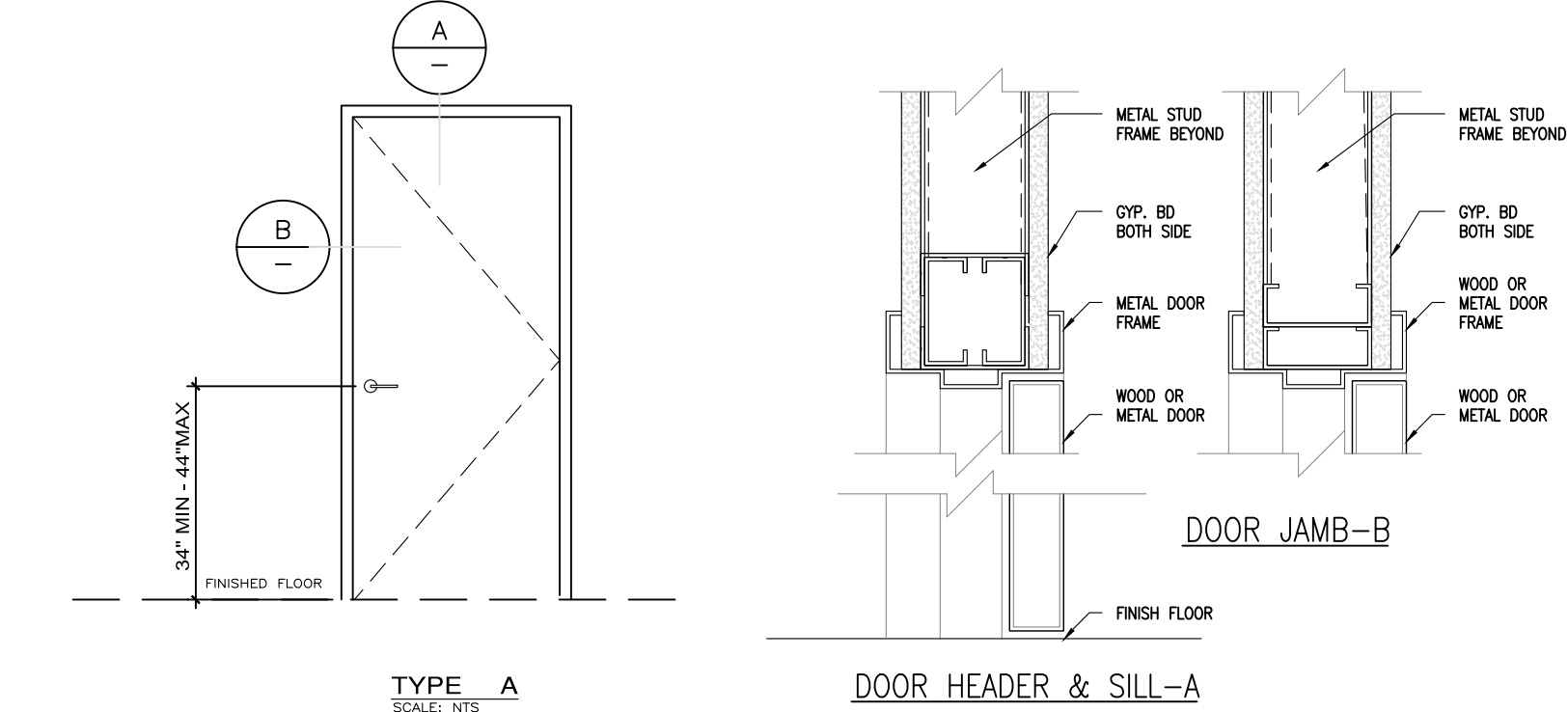
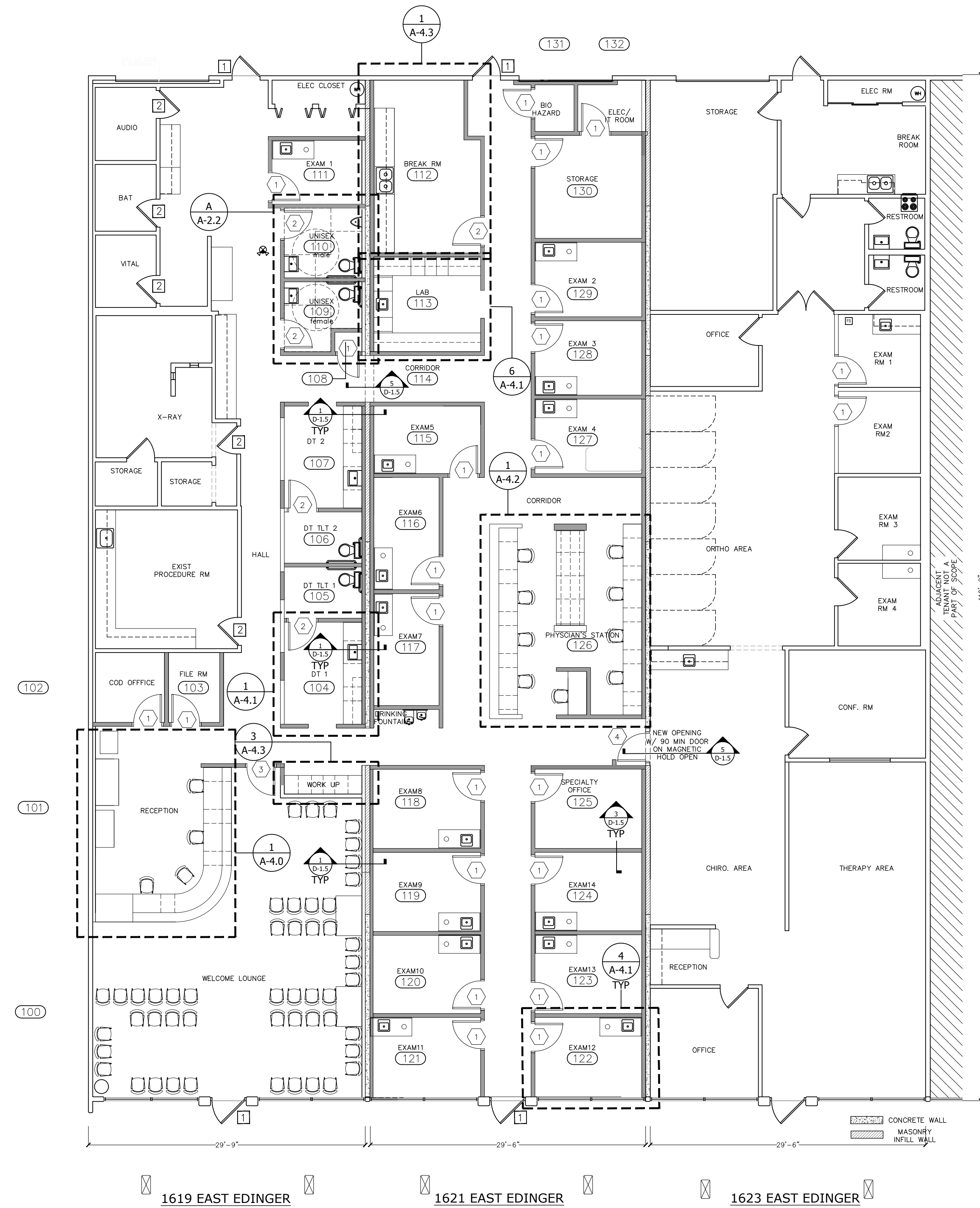

INTERIOR THRESHOLD DETAIL
SCALE: N.T.S.

EXTERIOR THRESHOLD DETAIL
SCALE: N.T.S.

PROPOSED PLAN LEGEND

- NEW WALL SEE DETAIL 3/ SHEET D-1-5
- EXISTING WALL TO REMAIN
- EXISTING STRUCTURAL CONCRETE WALL TO REMAIN INTACT
- EXISTING NON STRUCTURAL MASONRY WALL
- NEW DOOR
- EXISTING DOOR AND FRAME TO REMAIN
- EXIST. 3'-0" WIDE EXIT DOOR W/ LEVER HARDWARE OPENABLE WITHOUT THE USE OF A KEY OR ANY SPECIAL KNOWLEDGE OR EFFORT.
- EXIST. 3'-0" WIDE DOOR TO REMAIN

PROPOSED FLOOR PLAN
SCALE: 1/8" = 1'-0"

EDWIN MOHABIR
EM
 ARCHITECT, INC.
 SANTA CLARITA, CA 91381
 24979 CONSTITUTION AVE. #1435
 EDWINMOHABIR@GMAIL.COM
 TEL: 323-459-8809

ARCHITECT
 EDWIN R. MOHABIR
 C23674
 Exp. 02-28-21
 STATE OF CALIFORNIA

OWNER/ADDRESS:
Concentra
 1619-1623 EDINGER AVE.
 SANTA ANA, CA 92705

CONTACT:
 LISA STEWART
 CONSTRUCTION MANAGER
 (661)481-1851

SCOPE:
 TENANT IMPROVEMENT
 AND OFFICE EXPANSION

NOTES/REVISIONS:

PROJECT DATA:

DATE:	07-14-2020
ARCHITECT:	EM
CHECKED BY:	EM
DRAWN BY:	EM
PROJECT NO.:	1906
SCALE:	1/8" = 1'-0"

SHEET NAME/NUMBER:
PROPOSED FLOOR PLAN AND DOOR SCHEDULE
A-2.1

EXHIBIT 7

12-280

EXHIBIT 8

12-382

PARKING DEMAND STUDY

CONCENTRA

OCCUPATIONAL MEDICINE & URGENT CARE
1619, 1621, 1623 East Edinger Avenue
in the City of Santa Ana

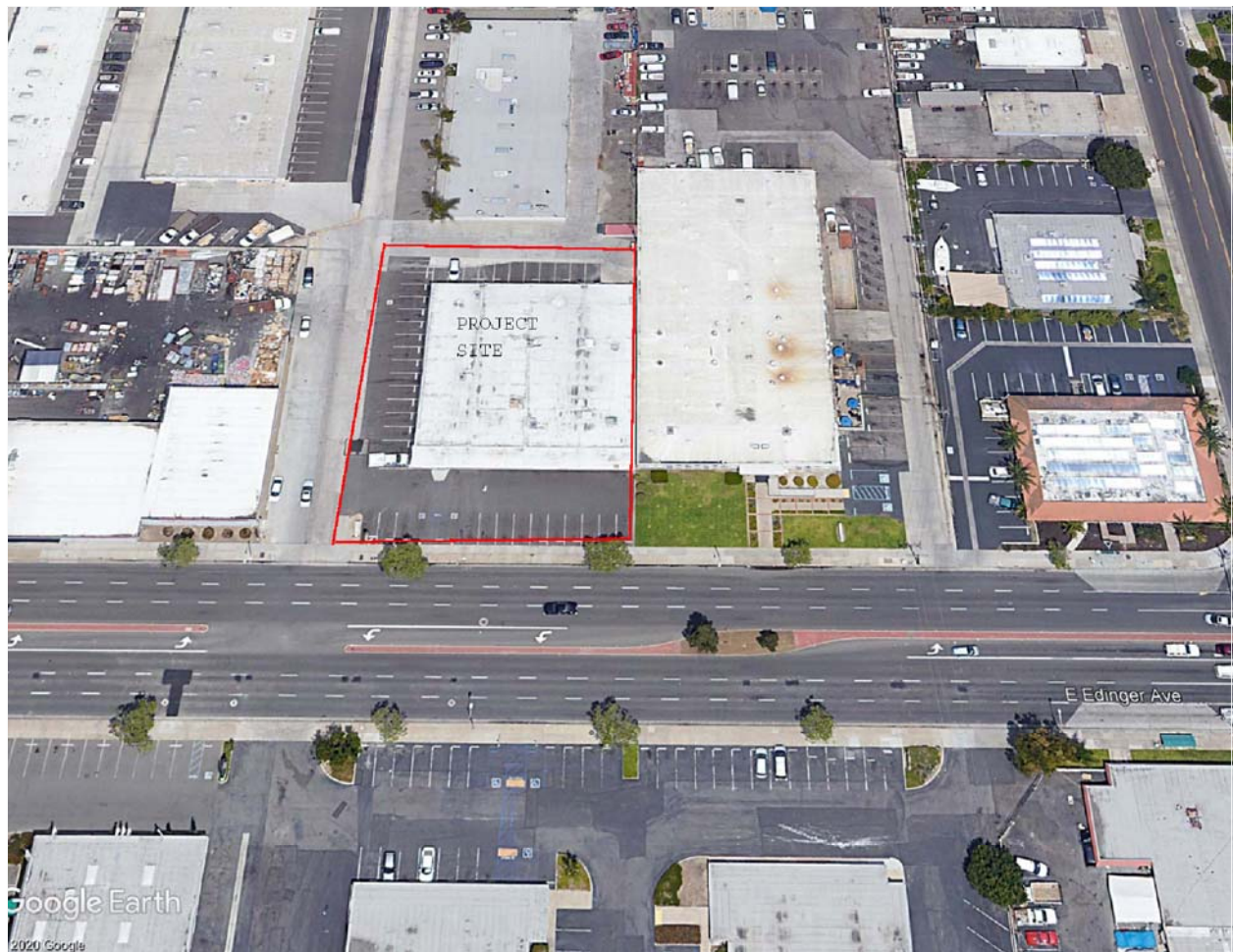

Google Earth

Prepared by:
Overland Traffic Consultants, Inc.
952 Manhattan Beach Bl, #100
Manhattan Beach, California 90266
(310) 545-1235



EXECUTIVE SUMMARY

This report provides an evaluation of the parking demand for the proposed project at a site located at 1619, 1621, 1623 and 1625 East Edinger Avenue in the City of Santa Ana. The Project is located on the north side of East Edinger Avenue between South Lyon Street and Grand Avenue. There is a 12,800 square foot building existing on the site. The building is separated into four 3,200 square foot units. A permitted and occupied 3,200 industrial medical office is located within the 1619 East Edinger Avenue space of the building and a 3,200 square foot manufacturing business operates within 1625 East Edinger Avenue space of the building. The Project will:

- Expand the existing industrial medical office by an additional 3,200 square feet in the 1621 East Edinger Avenue space; and
- Provide entitlements for the associated 3,200 square feet of physical therapy space within the 1623 East Edinger Avenue portion of the building.

Surface parking for the site is provided along the southern boundary of the site and along the east and north walls of the building. After modification for path of travel and trash enclosure, there will be a total of 40 shared parking spaces provided for the building. Vehicular access is provided from East Edinger Avenue with a driveway along the western boundary of the site that is shared with the neighboring uses.

The focus of this parking demand study is to determine the City of Santa Ana code required parking and determine if the 40 parking spaces provided on-site are sufficient to accommodate the peak parking demand of the Project along with the existing uses.

The City of Santa Ana code required vehicle parking is 54 spaces. Institute of Transportation Engineers parking demand for the land uses has been determined to be 40 spaces. Based on determined usage of the Project including employees and patients, it has been found that a peak parking demand of 37 parking spaces would be needed for the combined existing and project expansion uses. The peak demand has been determined to occur from 9 to 10 AM, Noon to 2 PM and from 6 to 7 PM. This peak demand would be accommodated on site with a surplus of 3 spaces.

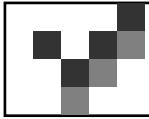

PARKING DEMAND STUDY

DESCRIPTION

The focus of the parking demand study is to document the City of Santa Ana code required parking for the mixed-use building located at 1619, 1621, 1623 and 1625 East Edinger Avenue and to determine the potential future peak parking demand of the building at full occupancy. Incorporated into this analysis is a goal to continue to provide sufficient on-site parking availability to accommodate the peak demand.

The 12,800 square foot building at 1619, 1621, 1623 and 1625 is currently permitted and occupied by a 3,200 square foot industrial medical office and 3,200 square foot manufacturing use. The Project, if approved, will allow for a 3,200 square foot expansion of the industrial medical office and the permit additional, associated, 3,200 square feet of physical therapy offices. Upon completion the building will house 6,800 square feet of industrial medical office with associated physical therapy and 3,200 square feet of manufacturing. A copy of the site plan is provided in Attachment A

Perpendicular parking spaces are provided along the southern boundary of the site and along the east and north walls of the building. A total of 40 on-site surface parking spaces are provided. Vehicular access is provided to/from East Edinger Avenue via a shared driveway. A channelized left turn pocket is provided on East Edinger Avenue.

PARKING DEMAND ANALYSIS PROCESS

The first step was to determine current City of Santa Ana code-parking requirement for the Project and the site as a whole. The vehicle parking requirement is 2 spaces per 1,000 square feet for the manufacturing (Section 41-1390) and 5 spaces per 1,000 square feet for the medical office (Section 41.1346).

Parking demand for the site may be reduced by use of the transit opportunities, cycling and walking in the area. The employees and patrons on site have an opportunity to use of mass transit instead of personal vehicles. Figure 1 provides a map of the Orange County mass transit services in the area.



Figure 1 Transit Services (Focused Orange County Transit Map)

Parking demand for the building based on national standards of the Institute of Transportation Engineers Parking Demand Manual was then determined based on the individual land uses and size.

Hourly parking demand for the building was then determined based on the individual land uses within the building including existing uses at code required parking rate (due to inability to collect accurate current demand) and for the Project based on operator input regarding estimated number of employees and hours and patient appointment rates and length of stay.

The estimated parking demand in this study was not reduced by anticipated transit usage to provide a conservative estimate of demand.



CITY OF SANTA ANA CODE PARKING REQUIREMENT FOR SITE

City of Santa Ana parking requirements have been calculated by the applying Zoning Code parking rates (Section 41-1390 & (Section 41-1346) as provided below in Table 1:

Table 1
City of Santa Ana Current Zoning Code Requirements

Land Use	Size	Parking Requirement	Code Required Parking
Existing			
Medical Office	3,200 sf	5 per 1,000 sf	16
Manufacturing	3,200 sf	2 per 1,000 sf	6
Subtotal Existing	6,400 sf		22
Proposed			
Medical Office Expansion	3,200 sf	5 per 1,000 sf	16
Physical Therapy	3,200 sf	5 per 1,000 sf	16
Subtotal Proposed	6,400 sf		32
Total Required	12,800 sf		54

There will be 40 parking spaces on-site with the Project. The building will have 14 fewer on-site parking spaces than would be required by City code. However, as provided in the following two sections, Institute of Transportation Engineers parking demand is within the limits of the parking supply and the proposed new uses operational parking demand for patients and employees hourly in addition to the existing use will be within the limits of the parking supply.

INSTITUTE OF TRANSPORTATION ENGINEERS PARKING DEMAND

The Institute of Transportation Engineers (ITE) publishes a Parking Demand Handbook that provides parking demand rates for many land uses. The demand in the handbook has been determined by collecting parking data at multiple sites throughout the day. Parking demand in the ITE Parking Demand Manual, 5th Edition for manufacturing is identified as 0.82 spaces per 1,000 square feet. Parking demand for medical clinics and medical/dental offices have also been evaluated in the manual. The average rate for a

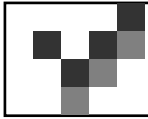

clinic is 3.89 spaces per 1,000 square feet with 12 sites studied. The average rate for a medical/dental office is 3.23 per 1,000 square feet with 117 sites studied. The ITE clinic rate was used in the estimate of the parking demand instead of medical/dental office because it is higher. The ITE based building's parking demand is provided on the following in Table 2.

Table 2
ITE Demand

Land Use	Size	85th Percentile Demand	Code Required Parking
<u>Existing</u>			
Medical Office	3,200 sf	3.89 per 1,000 sf	12
Manufacturing	3,200 sf	0.82 per 1,000 sf	3
Subtotal Existing	6,400 sf		15
<u>Proposed</u>			
Medical Office Expansion	3,200 sf	3.89 per 1,000 sf	12
Physical Therapy	3,200 sf	3.89 per 1,000 sf	12
Subtotal Proposed	6,400 sf		24
Total Required	12,800 sf		39

There will be 40 parking spaces on-site with the Project which exceeds the ITE estimated parking demand by one space.

HOURLY PARKING DEMAND BASED ON OPERATIONAL USE

Parking demand for the project and the building as a whole at 1619, 1621, 1623 and 1625 East Edinger Avenue has been determined based on current estimated demand with the Project land use demand added.

Existing Demand

The existing land uses include the 3,200 square foot industrial medical office and 3,200 square foot manufacturing use. Optimally, the building site would be surveyed to determine the existing uses demand within the parking lot. Unfortunately, this report has been initiated during the coronavirus business shutdowns and government stay put request. Parking demand counts during this time would not be representative of a typical



day. Therefore, existing parking demand was estimated as the code required parking for these two land uses. As shown in Table 1, existing parking demand is estimated as 22 parking spaces. In order to provide a conservative analysis, parking demand for every hour was estimated as 22 even though the demand would likely be smaller during different times of the day.

Project Demand

The Project parking demand was based on operations determined for the proposed 3,200 square foot industrial medical office expansion and the associated 3,200 square foot physical therapy office. Existing operators of the industrial medical office and physical therapy indicated the following:

Patients: 24 to 33 per day with 2 to 3 per hour

Employees: 9 new employees

The hours of operation are from 7 AM to 9 PM. As shown in Table 3 on the following page, the Project would create a parking demand of 11 to 15 parking spaces. When added to the existing parking demand for 22 spaces, the peak parking demand is 37 parking spaces. This peak occurs from 9 to 10 AM, noon to 2 PM and again in the evening from 6 to 7 PM. The building will have 6 more on-site parking spaces than would be needed according to parking demand based on operational use of the Project. Figure 2 on page 8, displays the hourly parking demand and found in Table 3 of the patients, the employees, the patients + employees, the existing uses and the combined total.

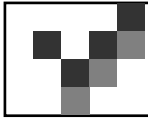

Table 3
SITE Parking Demand

40 Parking Spaces Provided

Time	Additon + Physical Therapy (Project)		Patients Parked	Employees Parked	Project Total Parking Demand	Existing Uses Parking Demand	Combined Demand Expansion + Existing	Parking Supply Available	Parking Surplus
	In	Out							
6 to 7 AM	0	0	0	0	0	0	0	40	40
7 to 8 AM	2	0	2	9	11	22	33	40	7
8 to 9 AM	3	0	5	9	14	22	36	40	4
9 to 10 AM	3	-2	6	9	15	22	37	40	3
10 to 11 AM	2	-3	5	9	14	22	36	40	4
11 to Noon	3	-3	5	9	14	22	36	40	4
12 to 1 PM	3	-2	6	9	15	22	37	40	3
1 to 2 PM	3	-3	6	9	15	22	37	40	3
2 to 3 PM	2	-3	5	9	14	22	36	40	4
3 to 4 PM	2	-3	4	9	13	22	35	40	5
4 to 5 PM	2	-2	4	9	13	22	35	40	5
5 to 6 PM	3	-2	5	9	14	22	36	40	4
6 to 7 PM	3	-2	6	9	15	22	37	40	3
7 to 8 PM	2	-3	5	9	14	22	36	40	4
8 to 9 PM	0	-3	2	9	11	22	33	40	7
9 to 10 PM	0	-2	0	0	0	0	0	40	40

33 new patients per day

Stay estimated 2 hours per patient max

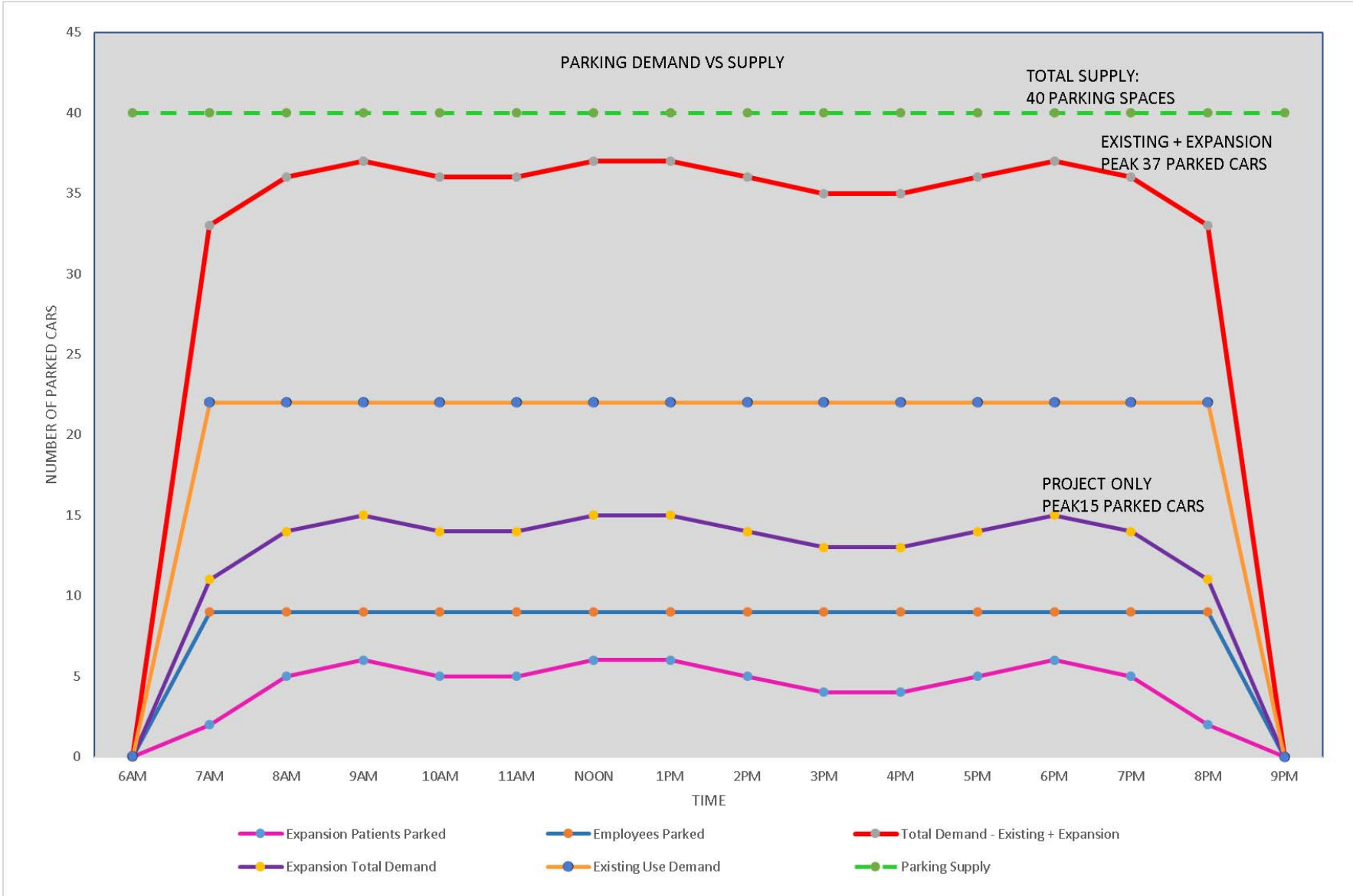

Figure 2, Chart of Hourly Parking Demand



PARKING DEMAND FINDINGS & SUMMARY

A demand parking analysis was conducted including the existing uses on site and the Project components including 40 parking spaces, 6,800 square feet of industrial medical office with associated physical therapy and 3,200 square feet of manufacturing.

- The site does not have enough parking to meet City code requirements for 54 parking.
- Enough parking is provided to meet estimated ITE Parking Demand of 40 spaces.
- Hourly parking demand based on operational use at 1619, 1621, 1623 and 1625 East Edinger Avenue site is estimated as a maximum of 37 parking spaces from 9 to 10 AM, noon to 2 PM and again in the evening from 6 to 7 PM.
- Peak parking demand for the site with the expansion of 3,200 square foot industrial medical office and 3,200 square foot physical therapy medical office is met with 3 surplus parking spaces.

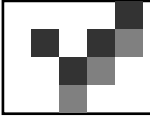

Overland Traffic Consultants, Inc.

**Attachment A
Proposed Project Site Plan**



OWNER ADDRESS:

Concentra

1619-1623 EDINGER AVE.
SANTA ANA, CA 92705

CONTACT:
LISA STEWART
CONSTRUCTION MANAGER
(661)481-1851

SCOPE:
TENANT IMPROVEMENT
AND OFFICE EXPANSION

NOTES/REVISIONS:

PROJECT DATA:

DATE:	04-22-2020
ARCHITECT:	EM
CHECKED BY:	EM
DRAWN BY:	EM
PROJECT NO.:	1906
SCALE:	1" = 10'-0"

SHEET NAME/NUMBER:

CUP PLOT PLAN

A-1.0

COMMON
DRIVEWAY

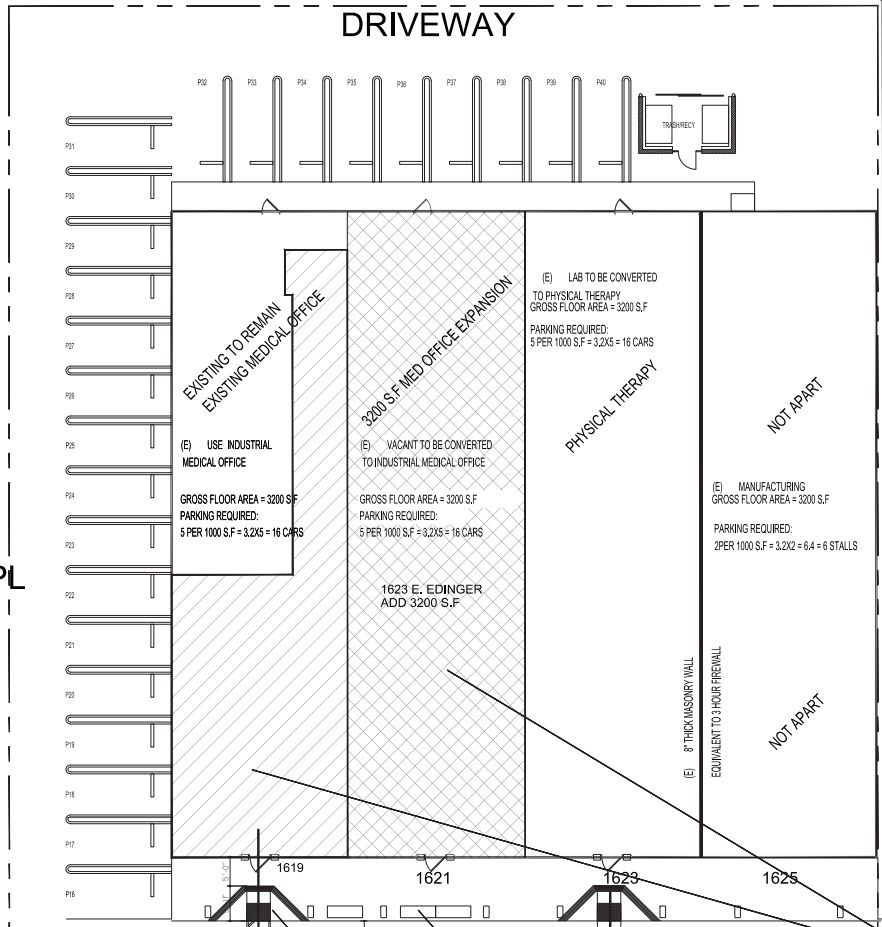

SUMMIT
COLLEGE

ITEM # A6 - PARKING TABULATION
PARKING REQUIRED:

1619 E. EDINGER	16 STALLS
1621 E. EDINGER	16 STALLS
1623 E. EDINGER	16 STALLS
1625 E. EDINGER	6 STALLS
TOTAL REQUIRED	54 STALLS
PARKING PROVIDED	40 STALLS
PARKING DEFICIT	14 STALLS
PERCENTAGE DEFICIT	26
VA REQUIRED	

PROJECT DATA

Project Address:
1619 E. Edinger Ave
1621 E. Edinger Ave
1623 E. Edinger Ave
APN: 402-241-10

Applicant:
Edwin Mohabir (323)459-8809

General Plan Land Use Designation Light Industrial
Allowable FAR ?
Zoning M1
Total Lot Area 33,839 square feet 0.78 ac.
Existing medical office = 3200 square feet
Proposed medical expansion = 3200 square feet
Proposed Physical Therapy = 3200 square feet
Existing Manufacturing = 3200 square feet

Parking Tabulation:
Gross floor area for all medical use = 9600 square feet
Parking required 5 per 1000 s.f. = 48 stalls
Manufacturing 2 per 1000 s.f. = 6.4 stalls
Total parking required = 54 stalls
Existing parking = 38 stalls
Existing ADA complying stalls = 2 stalls
Total provided = 40 stalls

Occupancy Type:
1619 E. Edinger Ave Group B Occupancy
1621 E. Edinger Ave Group B Occupancy proposed
1623 E. Edinger Ave Group B Occupancy proposed
1625 E. Edinger Ave Group F1 Occupancy
Construction type Type VB
Exterior walls Masonry
Roof Materials Panelized roof with wood beams and purlins
Non Sprinklered Building

There are no existing or proposed easements.
There are no fence around the property.

SHEET INDEX:

- A-1.0 CUP PLOT PLAN
- A-1.1 SITE PLAN
- A-1.2 PARKING CALCULATIONS
- A-1.3 AREA CALCULATIONS
- A-2.0 EXITING FLOOR PLAN
- A-2.1 PROPOSED FLOOR PLAN
- A-2.2 OCCUPANT LOAD AND EXITING PLAN
- C-1 COVER SHEET
- C-2 UTILITY PLAN
- L-1 PLANTING PLAN
- L-2 IRRIGATION PLAN
- L-3 DETAILS
- L-4 DETAILS
- L-5 DETAILS
- L-6 NOTES

LEGEND

--- POT: Accessible path of travel as indicated on plan is a barrier free access route without any abrupt level changes exceeding 1/4" if bevel at 1:2 max. slope, or vertical level changes not exceeding 1/4" and at least 48" in width. The surface is stable, firm, and slip resistant. Cross slope does not exceed 2% and slope in the direction of travel is less than 5% slope, unless otherwise indicated. Landing at doorways shall be 2% max.

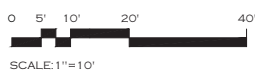

COMMON
DRIVEWAY

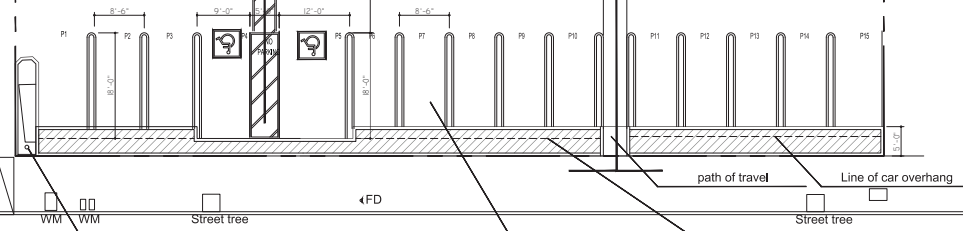

ITEM # A4
NON CONFORMING POLE SIGN
TO BE REMOVED.
MONUMENT SIGN IF DESIRED
MUST COMPLY TO SECTION
41-862 OF THE S.M.C.

ITEM # A1
PARKING LOT RE-STRIPE PER
SANTA ANA CITY STDS

ITEM # A2 & 3
LANDSCAPE SEE
LANDSCAPE PLANS